

Solar Square Decking Light

PLEASE CHARGE YOUR LIGHT FOR 3 DAYS BEFORE FIRST USE

User Guide

Thank you for choosing The Solar Centre's Square Decking Light. Please read these instructions carefully before installing your light.

Installing your Solar Square Decking Light

The batteries in your light do not come with any charge so the unit will need 3 days outside in a sunny spot to build up a base charge.

Before you take the time to recess your light it is important to think about the amount of light it will receive each day. Position the light in an area that gets good sunlight which is not obstructed by trees, foliage, buildings, fences or the shadows that these create. For best results mount the light horizontally. Failure to do this could result in you making alterations to your decking or patio for a light that will not work well in that location.

- 1: Create a 95mm by 95mm square hole that is 30mm deep.
- 2: Unscrew the four screws on the top of the light.
- 3: Remove the stainless steel top **(a)**.
- 4: Remove the plastic insert **(b)**.
- 5: Put the base **(c)** into the hole and screw into place if required.
- 6: Turn insert upside down and push button to turn on.
- 7: Replace the plastic insert.
- 8: Replace the stainless steel top.
- 9: Replace the original four screws on the top of the light.

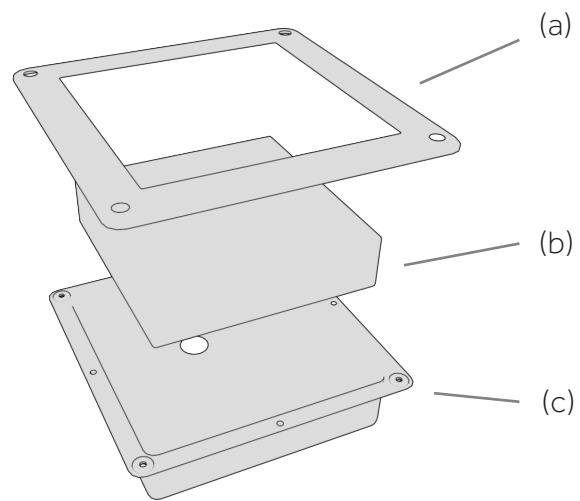

How it Works

During daylight hours, the sun charges the battery in the Solar Square Decking Light which then powers it after dark. The Solar Square Decking Light illuminates automatically at dusk and switches itself off automatically at dawn.

Changing the Batteries

- 1: Unscrew the four screws on the stainless steel surround and remove it.
- 2: The insert inside can now be removed.
- 3: Turn over the insert and remove the four screws.
- 4: Remove the rubber seal.
- 5: Replace the batteries with rechargeable AA NiMH batteries
- 6: Recycle old batteries
- 7: Reassemble light unit

Please note:

It is essential that the Solar Square Decking Light casing is completely flush to the ground once installed. If the light sits above ground level it can become a trip hazard. Please take extreme care before creating a hole in your property. There may be hazards underground such as cabling or pipes which could cause serious injury if damaged. The Solar Centre advises seeking the advice / services of a professional when installing the Solar Square Decking Light.

For customer support please contact:

The Solar Centre Ltd
Unit 5, Dencora Centre
Campfield Road
St Albans
Hertfordshire
AL1 5HN

T: 0845 094 1250

W: www.thesolarcentre.co.uk

E: info@thesolarcentre.co.uk

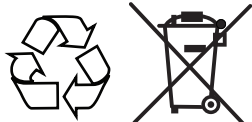

Made in China to Solar Centre Specification

 **solarcentre**
making solar that works