

GOODWE



User manual

EV Charger
HCA Series (7–
22 kW) G2

Version 1.3-2025-07-03

Copyright©GoodWe Technologies Co.,Ltd. 2025. All rights reserved.

This manual may not be reproduced in whole or in part or transmitted to any public platform without the prior written permission of GoodWe.

Trademarks

GOODWE and other GoodWe trademarks are trademarks of GoodWe. All other trademarks (including registered trademarks) mentioned in this manual are the property of GoodWe Company.

NOTE

The information in this user manual is subject to change due to product updates or other reasons. Unless otherwise specified, this manual cannot replace the safety instructions or labels on the device.

CONTENTS

1	About this manual.....	1
1.1	Scope.....	1
1.2	Target audience	1
1.3	Symbol definition.....	2
2	Safety precautions.....	3
2.1	General safety.....	3
2.2	Safety of the EV charger	3
2.3	Requirements for personnel.....	4
2.4	Declaration of conformity	5
3	Introduction to the product.....	6
3.1	Product overview	6
3.2	Use cases	7
3.3	Charging mode	9
3.4	Charger operating status	10
3.5	Functionality.....	10
3.6	Appearance	12
3.6.1	Parts description	12
3.6.2	Dimensions	14
3.6.3	Display description.....	16
3.6.4	Type plate	16
4	Testing and storage	17
4.1	Inspection prior to acceptance.....	17
4.2	Accessories	17
4.3	Storage	18
5	Assembly	19
5.1	Assembly specifications.....	19
5.2	Assembly.....	21
5.2.1	Moving the appliance	21
5.2.2	Mounting the charger (on the wall).....	22
5.2.3	Mounting the charger (on a post).....	23
5.2.4	Installation of the MID meter (optional).....	24
6	Electrical connection.....	25
6.1	Safety precautions	25
6.2	Connecting the RCBO cable	27
6.3	Connecting the mains cable.....	28
6.4	Connecting the communication cable	29
6.4.1	Connecting the RS485 communication cable.....	29
6.4.2	Connecting the LAN communication cable.....	30

NT6.4.3 Connecting the MID meter cable (optional)30

7 Commissioning31

7.1 Checks before switching on31

7.2 Switching operation.....31

7.3 Charging electric vehicles32

7.3.1 Online shop via SolarGo or the SEMS portal app.....32

7.3.2 Plan charging via the SolarGo or SEMS portal app33

7.3.3 AUTO start mode34

7.3.4 Charging via the RFID card34

8 System commissioning35

8.1 Display35

8.2 Setting and checking charger data via the SolarGo app (installations).....35

8.2.1 Downloading and installing the app35

8.2.2 Registering the charger36

8.2.3 Introduction to the main page.....37

8.2.4 Configure Wi-Fi.....38

8.2.5 Configuring charging mode39

8.2.6 More41

8.3 Setting and monitoring charger data via the SEMS Portal app (installations).....44

8.3.1 Downloading and installing the app44

8.3.2 Registering the end user account44

8.3.3 Logging in to the app45

8.3.4 Create attachment46

8.3.5 Configure charging mode.....47

8.3.6 Setting.....50

9 Maintenance54

9.1 Shutdown54

9.2 Removal of the charger54

9.3 Disposal of the charger.....54

9.4 Routine maintenance54

9.5 Troubleshooting55

10 Technical data.....57



1 About this Manual

This manual contains product data, installation instructions, a description of the electrical connection, commissioning, troubleshooting and maintenance of the charger. Please read this manual before installation and commissioning. All installers and users must be familiar with the product functions and features as well as the safety instructions. The manual is subject to change without prior notice. Further information on the product and the latest documents can be found at <https://en.goodwe.com>.

1.1 Scope

The manual applies to the chargers listed below (hereinafter referred to as "HCA").





- GW7K-HCA-20
- GW11K-HCA-20
- GW22K-HCA-20

1.2 Target audience

This manual is intended only for trained and experienced personnel. They must be familiar with the product, the relevant standards and electrical installations.

1.3 Symbol definition

In this manual, the graded warnings are defined as follows:

 DANGER
Indicates a high risk that could result in death or serious injury.
 WARNING
Indicates a moderate risk that could result in death or serious injury.
 CAUTION
Indicates a minor hazard that may result in minor or moderate injury.
 NOTE
Indicates emphasis and additions to the text. Or also refers to qualifications and working methods for solving product-related problems and saving time.



2 Safety precautions

Be sure to observe the following safety instructions during operation.

NOTE

The charger complies with the relevant safety regulations. Please observe all safety and precautionary instructions before use. Incorrect operation may result in personal injury or damage to property, as chargers are electrical devices.

2.1 General safety

NOTE

- The information in this user manual is subject to change due to product updates or other reasons. Unless otherwise specified, this manual does not replace the labels on the product or the safety instructions contained in the user manual. All descriptions in this manual are for guidance only.
- Before installation, read the user manual and familiarise yourself with the product and the precautions.
- All installation work should be carried out by trained and competent technicians who are familiar with local standards and safety regulations.
- To ensure personal safety, use insulated tools when operating the device and wear the necessary personal protective equipment. Protective equipment. Wear antistatic gloves, cloths and wrist straps when touching electronic devices to protect the charger from damage.
- Follow the instructions for installation, operation and configuration in this manual carefully. The manufacturer is not liable for damage to equipment or personal injury resulting from failure to follow the instructions. For more information on the warranty, visit: <https://en.goodwe.com/warranty>.

2.2 Safety of the EV- Charger



DANGER

- Do not attempt to dismantle the charger modules yourself. The charging cable must not be extended. Doing so could reduce the IP protection class or create a risk of electric shock.
- The device is only suitable for charging electric vehicles (hereinafter referred to as EV). Other devices must not be charged.
- After using the charging connection, please cover the charging plug properly and wrap the charging cable around the charger.
- The charger and cable must not be bent, kinked or tangled excessively. Otherwise, the device may be damaged.
- Before installation, maintenance and other operating procedures, disconnect the charger and its upstream switches.
- Touching the charging connection while the charger is running is strictly prohibited.











WARNING

Regularly check the cover and housing of the charger by visual inspection.

 **DANGER**

- All labels and warning markings should be visible after installation. Labels on the system must not be covered, defaced or damaged.
- The following warnings are located on the charger:

	<p>HIGH VOLTAGE HAZARD: High voltage is present during operation. Disconnect the device from the power supply and switch it off before working on it.</p>		<p>Delayed discharge. After switching off the power, wait 5 minutes until the components are completely discharged.</p>
	<p>Please read the user manual before starting operation.</p>		<p>There are potential risks. Put on the necessary personal protective equipment before starting work.</p>
	<p>High temperature hazard. Due to the risk of burns, the device must not be touched during operation.</p>		<p>The charger must not be disposed of with household waste. Dispose of the product in accordance with regulations or return it to the manufacturer.</p>
	<p>CE mark.</p>		<p>RCM mark.</p>
	<p>Brazil ANATEL mark.</p>		

2.3 e personnel requirements

NOTE

- The specialist personnel responsible for setting up or maintaining the system must be trained in safety measures and correct operation.
- Only authorised specialists or trained personnel may assemble, operate, maintain and replace the system as a whole or partly, operate, maintain and replace the system.



2.4 Declaration of conformity

EU

The product with wireless communication modules available on the European market complies with the following directives:

- Radio Equipment Directive 2014/53/EU
- Directives 2011/65/EU and (EU) 2015/863 (RoHS) on the restriction of the use of certain hazardous substances

GB

The product with wireless communication modules available on the British market complies with the following directives:

- Radio Equipment Regulations 2017
- The Restriction of Hazardous Substances in Electrical and Electronic Equipment 2012 (S.I. 2012/3032)

Brazil

The product with wireless communication modules available on the Brazilian market complies with the following directives:

- Incorporates product approved by Anatel under number 06795-24-02673.
- This equipment is not entitled to protection against harmful interference and may cause interference to duly authorised systems. Further information can be found on the ANATEL website www.gov.br/anatel/pt-br.

NOTE

- 2.4G WLAN, operating frequency: 2412–2472 MHz, max. e.i.r.p.: 18.99 dBm
- BLE 1M & 2M, operating frequency: 2402–2480 MHz, max. e.i.r.p.: 2.99 dBm
- RFID 13.56 MHz, max. e.i.r.p.: -47.50 dBm

3 Introduction to the product

3.1 Product overview

The HCA series product is a mains household charger, mainly for charging electric vehicles. It can communicate with an inverter to use PV energy to charge electric vehicles, retrieve smart meter data via the inverter for dynamic load management, and communicate with a MID meter (MID-certified smart meter) for billing purposes. Supports RFID card start, APP start and automatic start by plugging in the charging plug. Also supports charging protection, network monitoring, etc.

Model

The manual applies to the chargers listed below

- GW7K-HCA-20
- GW11K-HCA-20
- GW22K-HCA-20

Model description

GW11K-HCA-20



No	See	Explanation
1	Brand code	GW: GoodWe
2	Rated power	<ul style="list-style-type: none"> • 7 K: Nominal power is 7 kW. • 11 K: Nominal power is 11 kW. • 22 K: Nominal power is 22 kW.
3	Series	HCA: HCA series
4	Generation	20: the second generation.



3.2 Applications

With PV & battery

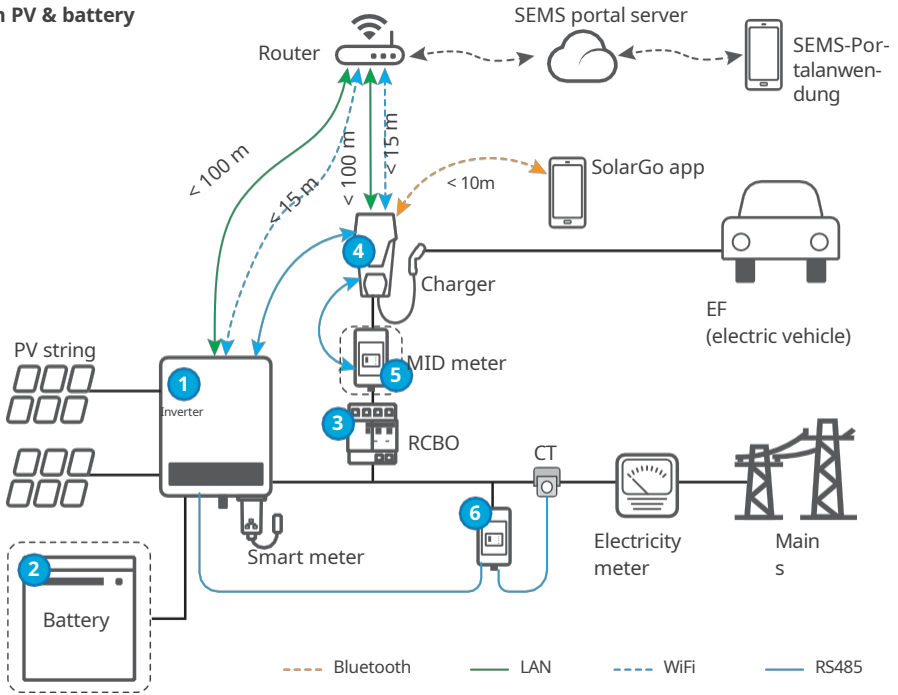

Without PV or battery

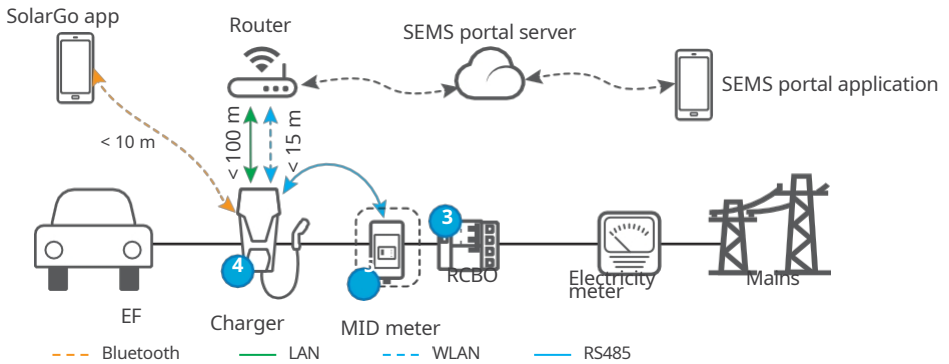

No.	Parts	Description
1	Inverter	Grid-connected PV and hybrid inverters from GoodWe.
2	Battery	Batteries designed to work with GoodWe hybrid inverters.
3	RCBO	Provides residual current and overcurrent protection for the charger. When purchasing, please contact the charger manufacturer.
4	Charger	GoodWe charger from the HCA series.
5	MID meter	Records the power consumption data of the EF charger, which can be used for billing purposes.
6	Smart meter	Included with the inverter or available from the inverter manufacturer.

Circuit diagram

The circuit diagram for the HCA charger is provided below:

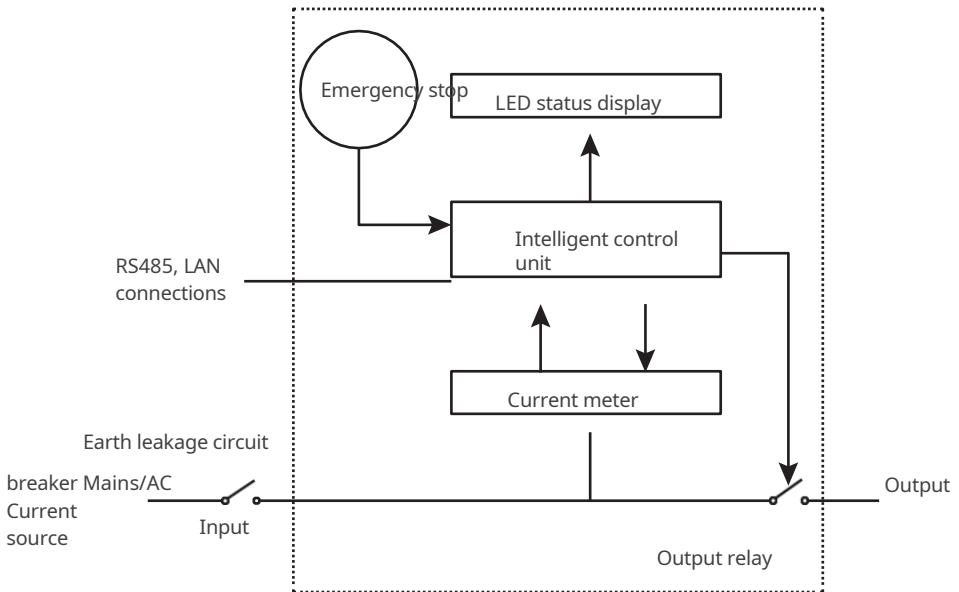

- The RS485 connection is used for communication with PV inverters or MID meters.
- The LAN port is used for communication with the router.
- For single-phase and three-phase EV chargers, the input connection is used to connect to a three-core single-phase or five-core three-phase power cable.
- The output connection is used to connect to the charging plug.
- Emergency stop refers to the emergency stop button.

Mains types

Single-phase scenario:

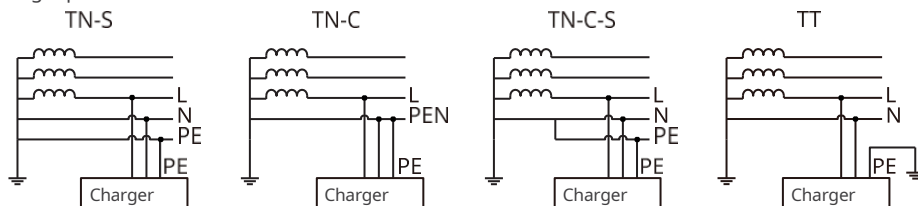

Three-phase scenario:

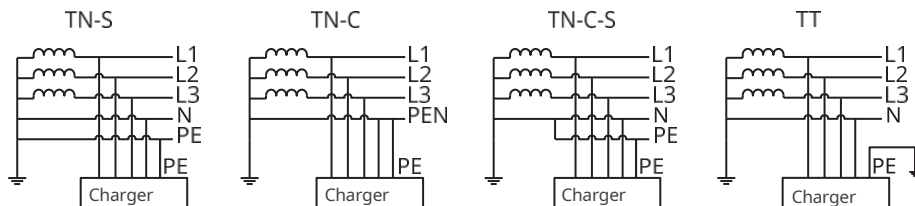

3.3 Charging mode

NOTE

In "PV Priority" and "PV + Battery" modes, the charging power of the EF charger is limited by the maximum output power of the inverter.

Fast

The charger uses electricity from the grid, PV or batteries to charge electric vehicles. The output power of the charger corresponds to the nominal output power of the charger by default. Users can set an output power that does not exceed the nominal output power.

PV priority

Only PV power is used to charge the electric vehicle. Loads, which may be grid loads or emergency power loads, take priority over PV power consumption. The remaining power is used to charge the electric vehicle.

PV + battery

The PV power and the battery are used to charge the electric vehicle. Loads, which may be grid loads or emergency loads, have priority in power consumption. The remaining power is used to charge the electric vehicle.

3.4 Charger operating status

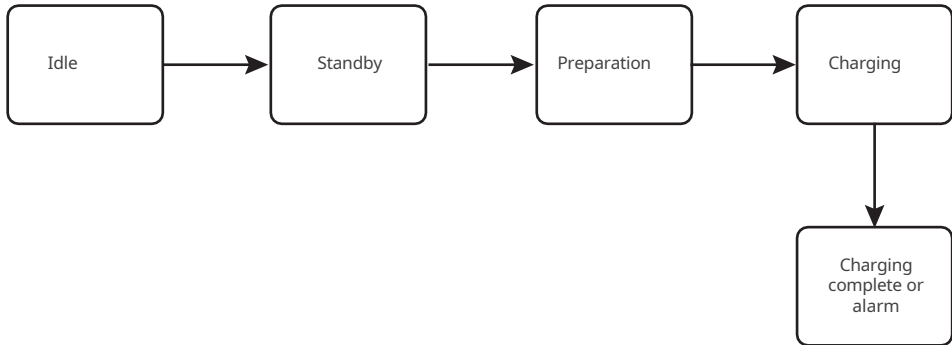

3.5 Functionality

NOTE

- The maximum charging power of the charger is limited by the maximum charging power of the vehicle's on-board charger (OBC).
- The minimum starting current for each phase of the charger is 6 A. The minimum charging power is 1.4 kW for single-phase charging and 4.2 kW for three-phase charging.
- Three-phase chargers support single-phase, two-phase and three-phase charging, but the actual charging power is influenced by the OBC. When a three-phase charger charges a vehicle that only supports single-phase charging, its maximum charging power is 1/3 of the charger's rated output power. When a three-phase charger charges a vehicle that only supports two-phase charging, its maximum charging power is 2/3 of the charger's rated output power.

Dynamic load control

After dynamic load control is activated, the charger uses the meter data received and the set mains connection current to balance the charging speed (or even pause the charging process) to prevent the main fuse from tripping. If the actual current drawn is close to the set mains connection current, the charger reduces the charging power until the charging process is interrupted to prevent tripping. The charger restarts automatically as soon as the difference between the set mains connection current and the current drawn from the mains meets the charger's start conditions.

Ensure minimum charging power

If the energy from the PV or PV + battery is insufficient, the charger can receive support from the grid or the battery. This allows the desired power output to be maintained when the "Ensure minimum charging power" function is activated. The function is only available in "PV priority" or "PV + battery" modes. Users can activate the function via the SolarGo app or SEMS app.



Status	Explanation
ON	Continue charging with support from the grid and the battery to ensure the minimum power required for charging (1.4 kW for 7 kW chargers, 4.2 kW for 11/22 kW chargers).
OFF	Interrupt charging when there is no longer any PV surplus.

Phase switch

NOTE

The phase switch function is only available for three-phase chargers.

Status	Explanation
ON	If the total input power is less than 4.2 kW, the charger switches automatically switches to single-phase charging mode to avoid purchasing electricity from the grid or shutting down. The minimum charging power in single-phase charging mode is 1.4 kW. (The phase switching time is approx. 3 minutes)
OFF	The charger remains in three-phase charging mode.

Safe and reliable

- The charger has an IP66 protection rating and the charging plug has an IP55 protection rating. With its high performance, the charger is particularly dustproof and waterproof, which means it can be operated and maintained outdoors.
- To protect the product and ensure safe operation, the device is equipped with overvoltage and undervoltage protection, overload protection, short-circuit protection, leakage current protection, earthing, overtemperature protection, EMS protection and lightning protection.

3.6 Appearance

3.6.1 Parts description

Charger

Type one

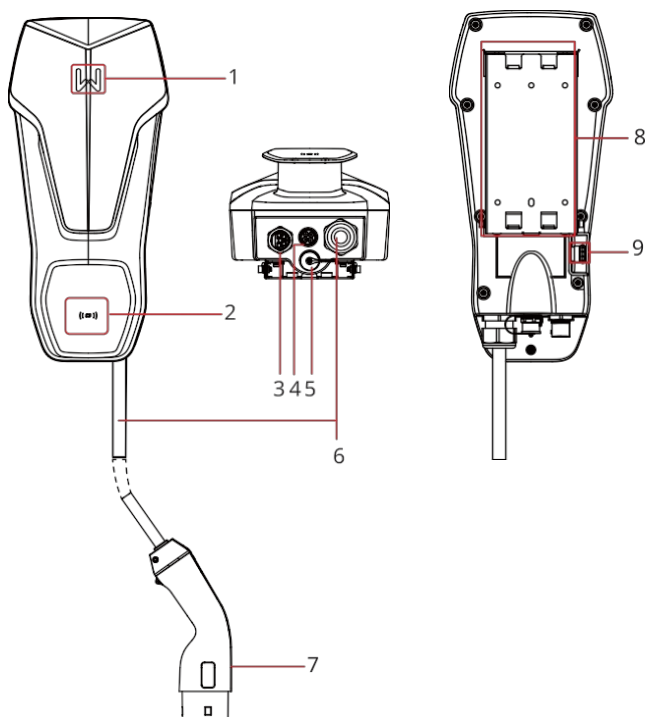

Type two

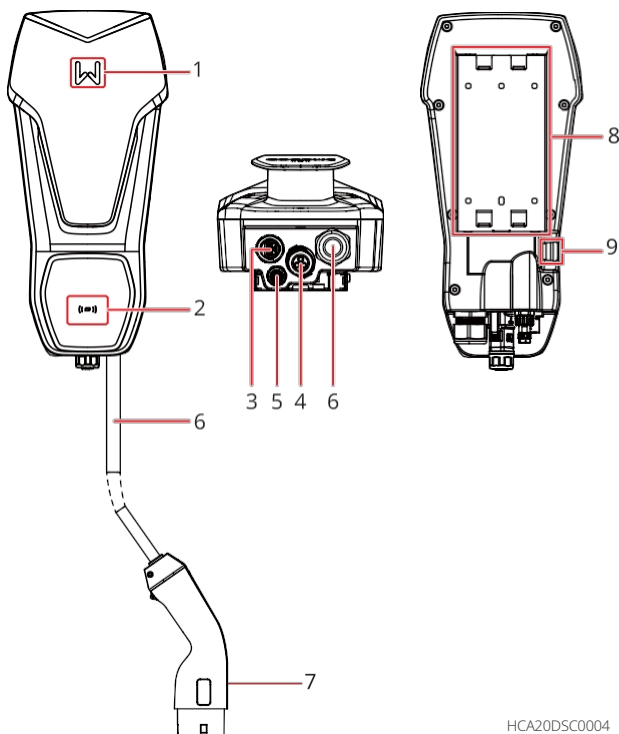

HCA20DSC0004

No	Parts	Description
1	Display	Indicates the operating status of the charger.
2	RFID card area	Tap the card to activate the charging process.
3	Input connection for mains cable	Connection with single-phase or three-phase mains input cable.
4	RS485 communication port	Connects the RS485 communication cable of an inverter or meter.
5	LAN communication port	Connects the communication cable of a router.
6	Charging cable	-
7	Charging plug	Connects to the EF charging port.
8	Mounting plate	Secures the charger to the bracket.
9	Emergency stop button	Used for emergency shutdown.



presentation

(Optional) Distribution board

GW7K-HCA-20

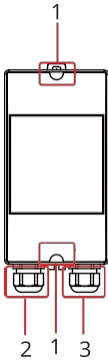

GW11K-HCA-20 and GW22K-HCA-20

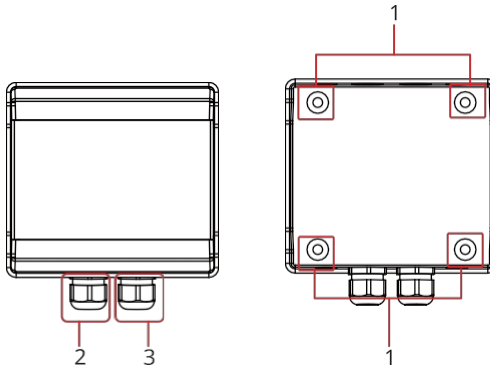

- 1. Mounting holes
- 2. Input connection for power cord
- 3. Input connection for power cord

(Optional) Post

GW7K-HCA-20

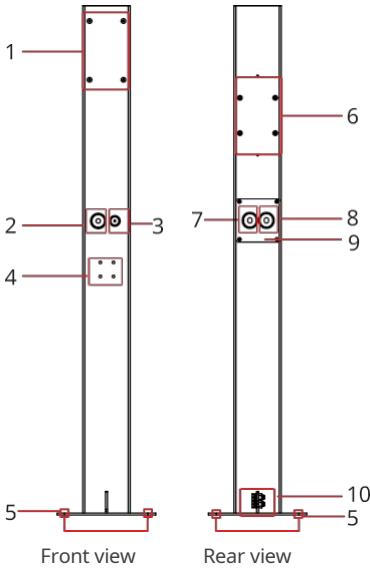

GW11K-HCA-20 and GW22K-HCA-20

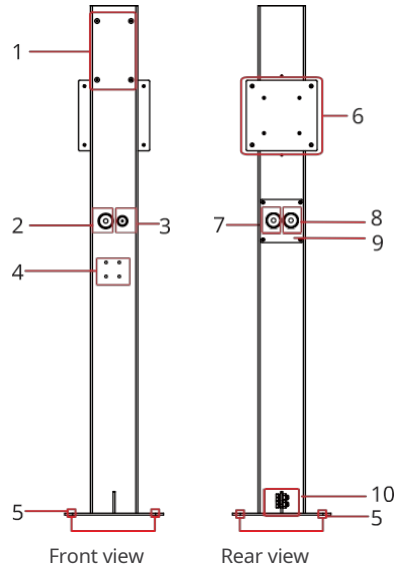

- 1. The mounting position of the charger
- 2. Power cable connection between RCBO and charger
- 3. Communication cable connection
- 4. Installation position of dummy socket
- 5. Hole position for base mounting
- 6. RCBO installation position
- 7. RCBO Input power cable
- 8. Power cable connection between RCBO and charger
- 9. Operating plate
- 10. PE connection

3.6.2 Dimensions

Charger

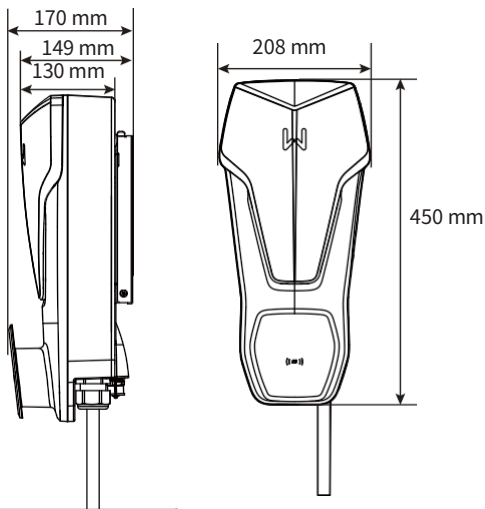

(Optional) RCBO distribution board

GW7K-HCA-20

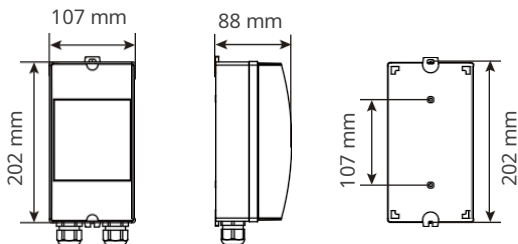

GW11K-HCA-20 and GW22K-HCA-20

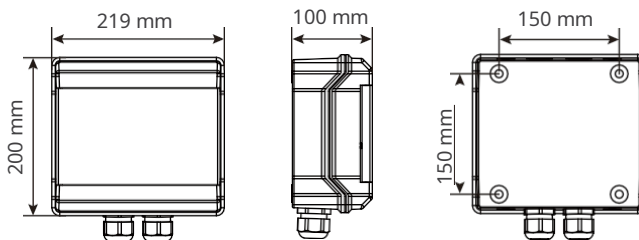

(Optional) Post

GW7K-HCA-20

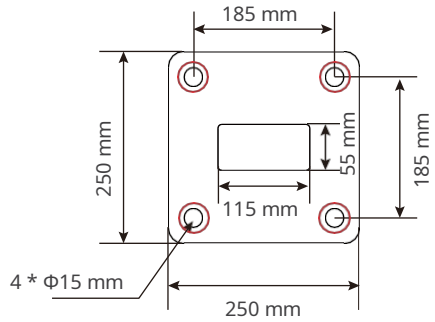
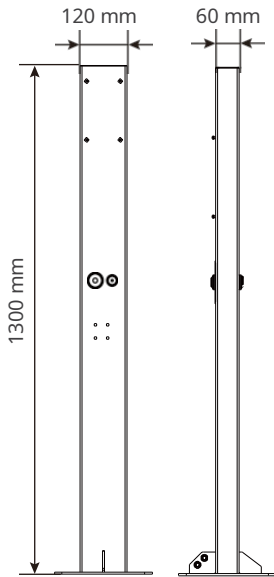

Bottom view of the post

GW11K-HCA-20 and GW22K-HCA-20

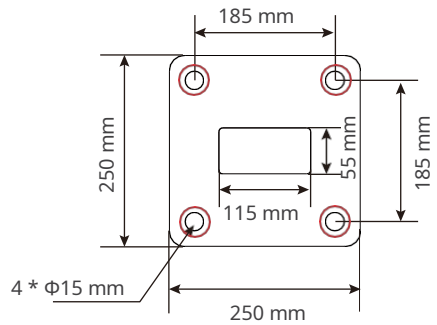
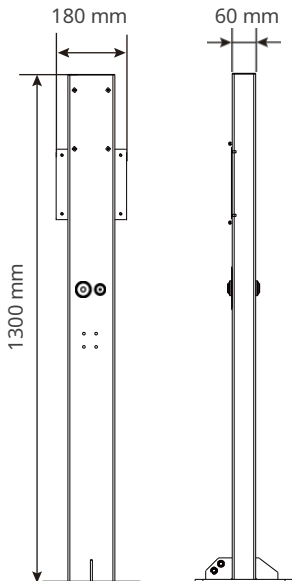

Bottom view of the post



(Optional) MID meter

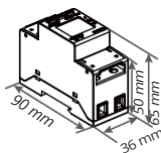
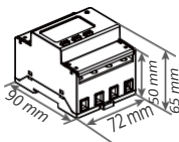

3.6.3 Display description

Display	Colour	Explanation
	Green ON	The charger is in standby mode.
	Green flashing	The charger is being upgraded.
	Blue ON	The charger is charging.
	Red ON	An error has occurred.
	The status of the indicator light in the event of abnormal activation of the RFID card charging process	
	Red light illuminates for 2 seconds	Tap the card before connecting the charging plug to the EF.
	Red light flashes twice	Charger and card do not match.

3.6.4 Type plate

The type plate is for reference only.

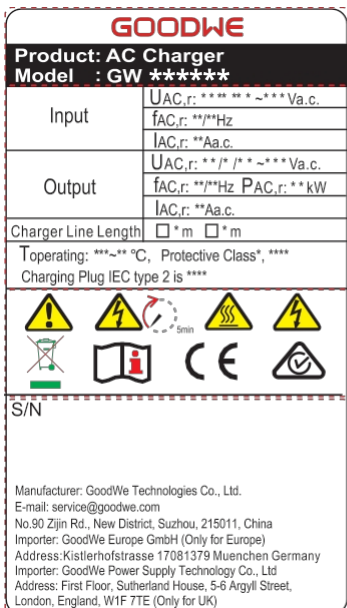

GOODWE trademark, device type and product model

Technical data

Safety symbols and Certification marks

Address and serial number

4 Inspection and Storage

4.1 Inspection before acceptance

Check the following items before accepting the product.

1. Check the packaging for damage such as holes, tears, deformations and other signs. Do not unpack and contact the supplier as soon as possible if you find any damage.
2. Check the charger model. If it does not match the order, do not unpack the product and contact the supplier.
3. Check your devices for correct models, completeness and intact appearance.
Contact the supplier as soon as possible if you find any damage.

4.2 Accessories

⚠ WARNING

Connect the cables to the terminals provided. The manufacturer is not responsible for damage to property if other terminals are used.

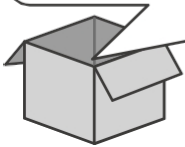
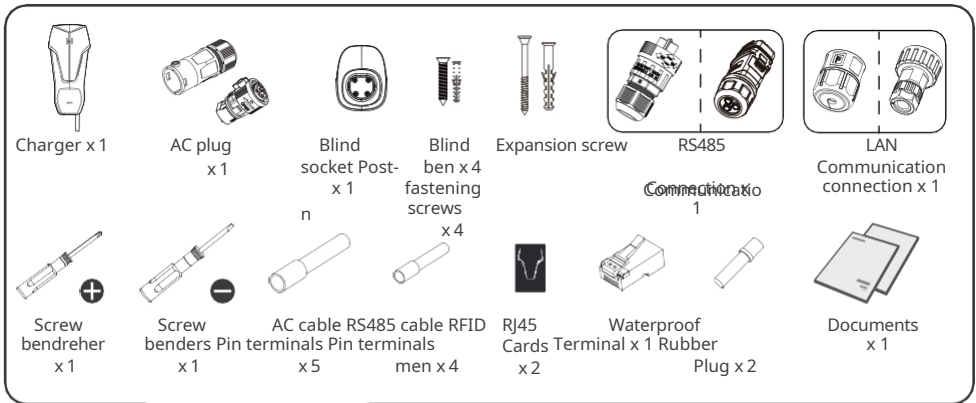

(Optional) GW7K-HCA-20

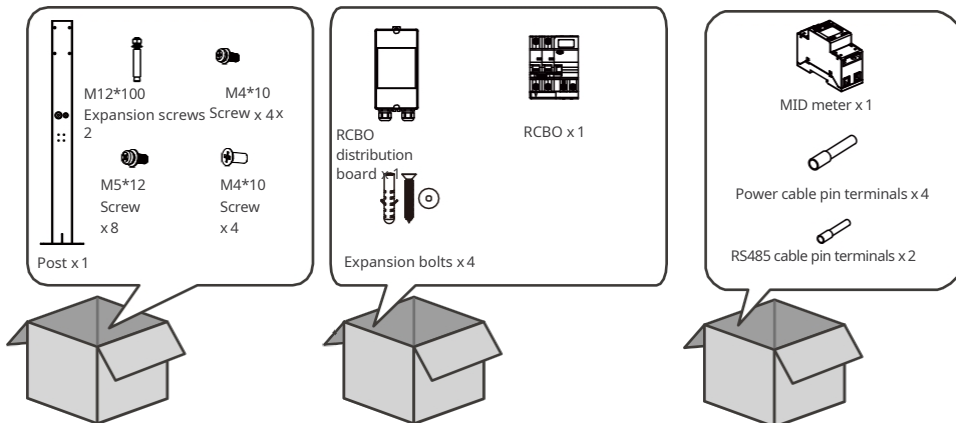

(Optional) GW11K-HCA-20 and GW22K-HCA-20

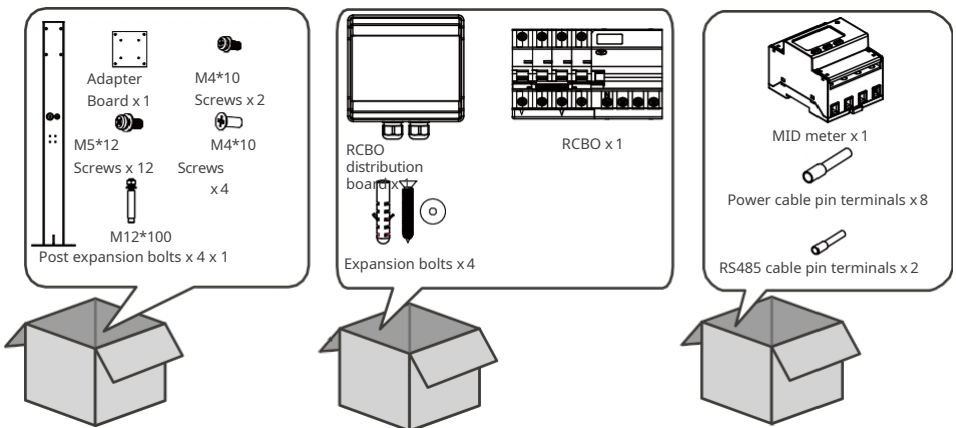

4.3 Storage

If the device is not to be installed or used immediately, the storage environment must meet the following requirements:

1. Do not unpack the outer packaging and do not discard the desiccant.
2. Store the device in a clean place. Ensure that the temperature and humidity are appropriate and that no condensation forms.
3. When storing the chargers, the height and stacking direction should comply with the instructions on the packaging.
4. The devices should be stacked with care so that they cannot fall over.
5. If the device has been stored for a long time, it should be checked by specialists before use.

5 Assembly

5.1 Installation specifications

Requirements for the installation environment

1. The system must not be installed near flammable, explosive or corrosive materials.
2. Do not install the system in an easily accessible location. High temperatures occur during operation of the system. Do not touch the surface, as there is a risk of burns.
3. When drilling holes, take care not to damage any water pipes or cables in the wall.
4. Set up the device in a protected location.
5. The installation site should be well ventilated to allow heat dissipation and provide sufficient space for operation.
6. Systems with a high degree of protection against ingress may be installed both indoors and outdoors. The temperature and humidity at the installation site should be within the required ranges.
7. The system should be installed at a height that is suitable for operation and maintenance, connections and checking displays and labels.
8. The device should not be installed at an altitude of more than 2000 metres above sea level.
9. Install the system out of reach of electromagnetic interference fields.

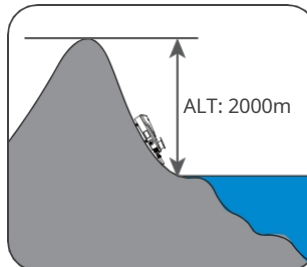
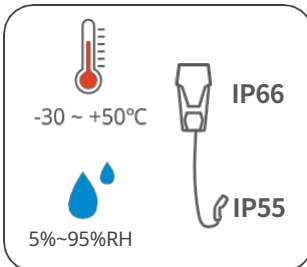
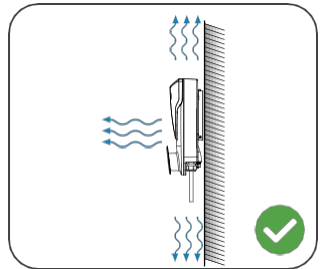
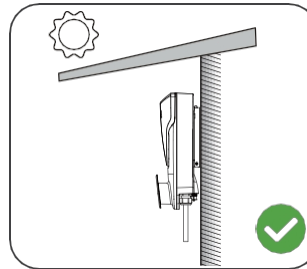
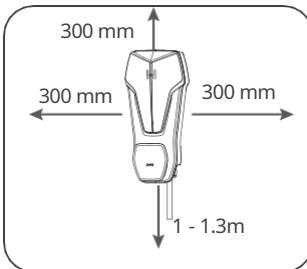
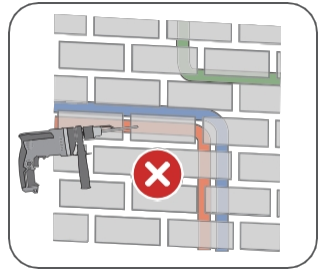
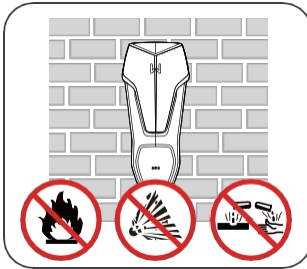

Mounting bracket instructions

- The mounting bracket should be fireproof and non-combustible.
- Install the device on a surface that is stable enough to support its weight.

Instructions for the angle of inclination

- The charger is best installed vertically.
- Do not install the device upside down, tilted forwards, tilted backwards or horizontally.

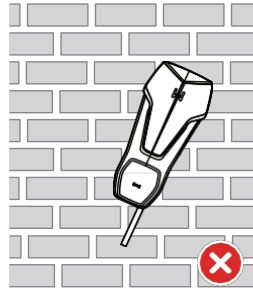
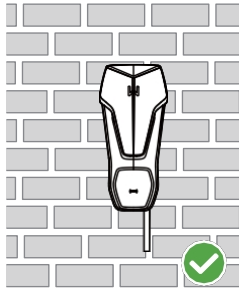
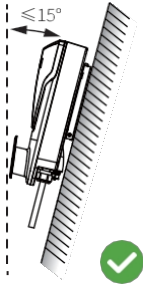

Instructions for mounting tools

The following tools are recommended for equipment installation. Use other additional tools as necessary.



5.2 Installation

5.2.1 Moving the device



Move the device to the desired location before setting it up. Follow the instructions below to avoid injury and damage to property.

1. Take the weight of the system into account when moving it. Use sufficient personnel.
2. Wear safety gloves.
3. Keep the system balanced when moving it.



5.2.2 Installing the charger (on the wall)

NOTE

- When drilling holes, take care not to damage any water pipes or cables in the wall.
- Wear safety goggles and a dust mask when drilling.
- The device should be securely mounted so that it cannot fall down.

Step 1 Remove the mounting plate from the charger.

Step 2 Mount the mounting plate, the RCBO distribution board and the dummy socket.

Hold it horizontally against the wall and mark the holes to be drilled.

Step 3 Drill holes using the hammer drill.

Step 4 Secure the mounting plate, the RCBO distribution board and the dummy socket to the wall using the expansion screws.

Step 5 Mount the charger on the mounting plate and secure the mounting plate.

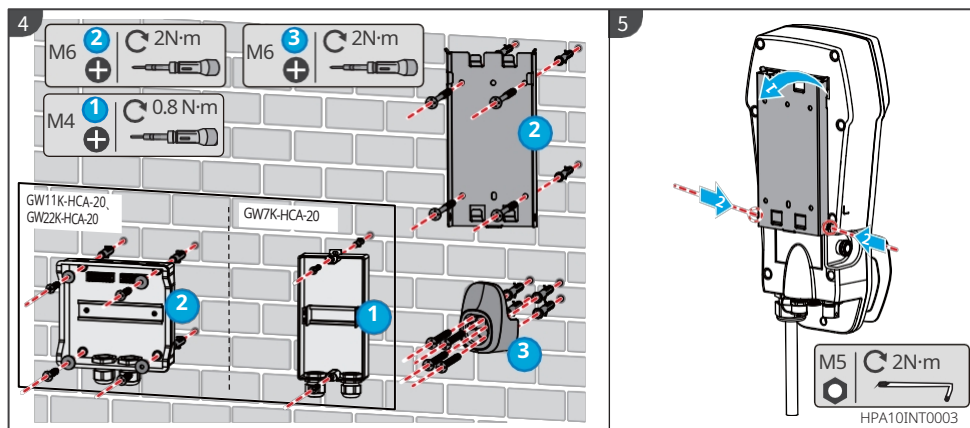
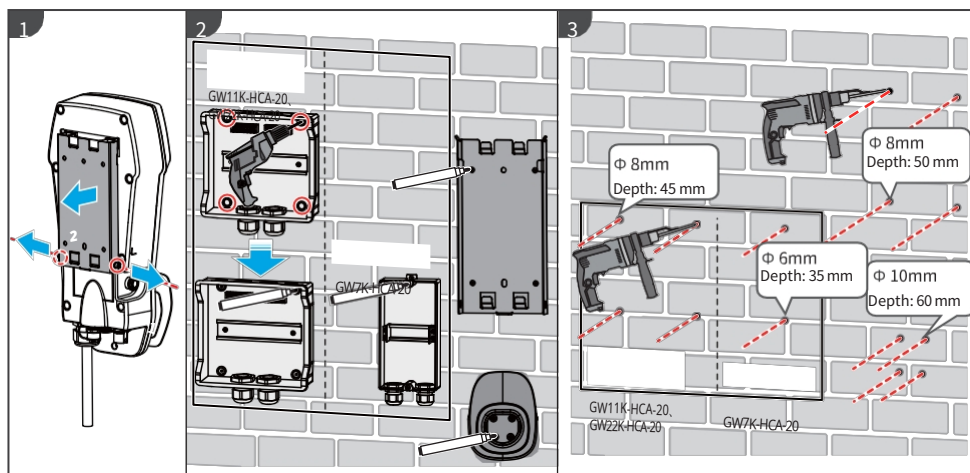

5.2.3 Mounting the charger (on the post)

NOTE

If you wish to install the charger on a base, purchase one from the manufacturer.

Step 1 Remove the operating plate from the post.

Step 2 Place the post vertically on the ground and mark the holes to be drilled. A cable tunnel with a diameter of 60 mm must be routed through the ground. **Step 3** Use a hammer drill to drill holes 75 mm deep with a diameter of 15 mm. **Step 4** Feed the embedded cable through the post, secure the charger to the floor using the expansion plugs and close the free mounting holes with screws. **Step 5** Mount the RCBO distribution board and adapter board on the post.

Step 6 Mount the dummy socket on the post. **Step 7** Remove the mounting plate from the charger. **Step 8** Mount the mounting plate on the post.

Step 9 Mount the charger on the mounting plate.

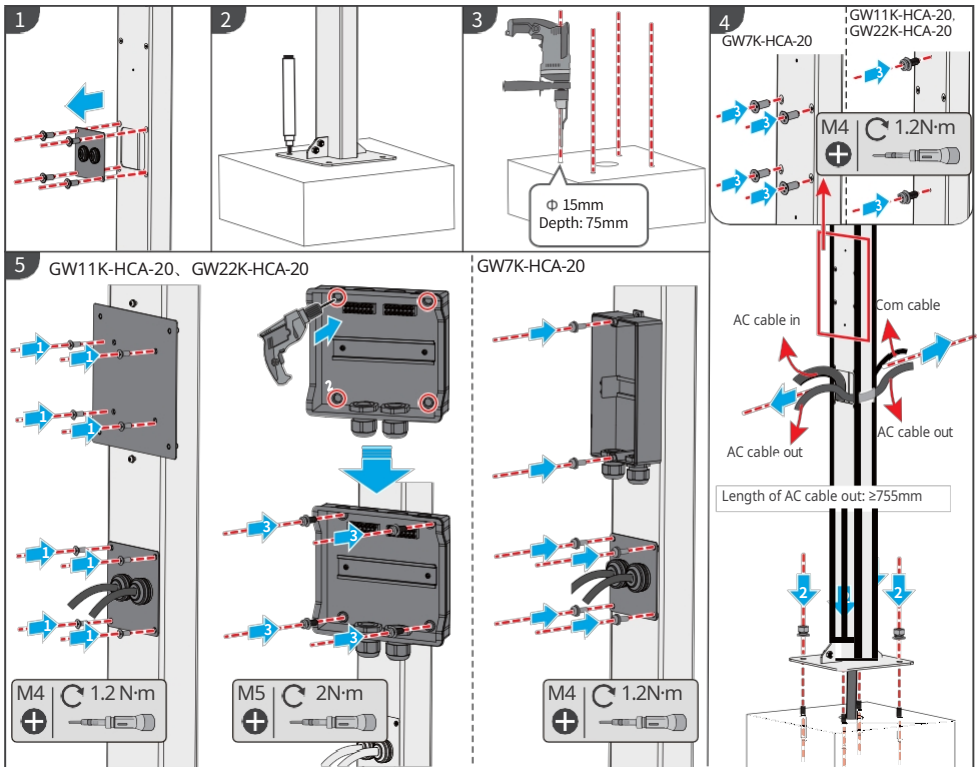

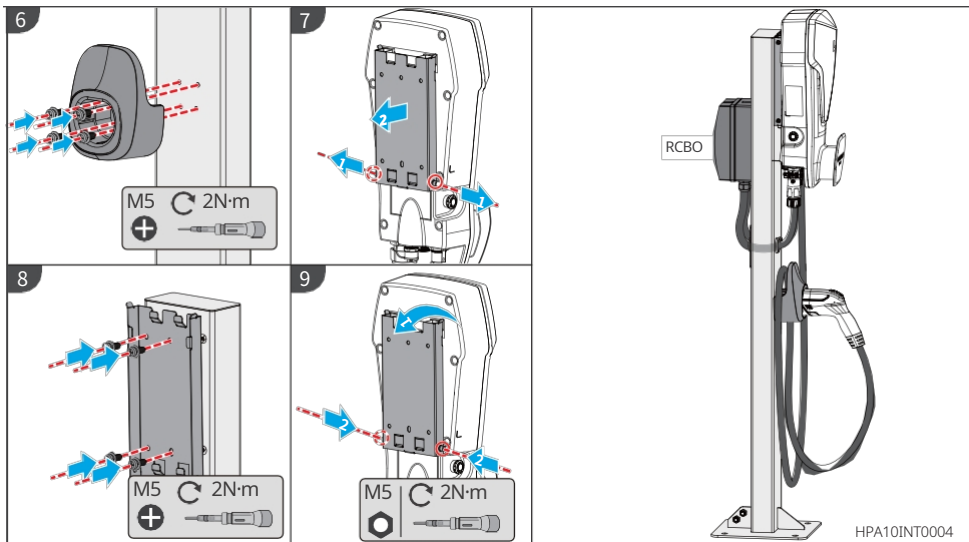

5.2.4 Installation of the MID meter (optional)

NOTE

If necessary, contact the manufacturer to purchase a MID meter.

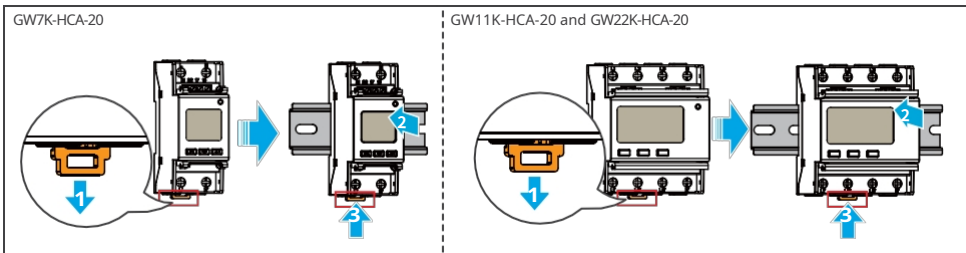

6 Electrical Connection

6.1 Safety precautions



DANGER

- Operating functions, cables and component specifications must be observed when making electrical connections.
- Disconnect the upstream switch before making electrical connections. Do not work while the power is on. This may result in electric shock.
- Bundle cables of the same type together and store them separately from cables of other types. Do not store cables in a twisted or crossed position.
- If the cable is under excessive tension, its connection may be faulty. Allow for a certain length of cable before connecting to the charger.
- When crimping the terminals, the stripped cable end must be in full contact with them. Do not crimp the cable sheath with the terminal. Otherwise, the charger cannot be operated, or its terminal block may be damaged during operation due to heating and other phenomena caused by an unreliable connection.



WARNING

- Connect the mains input cables correctly to the "L1", "L2", "L4", "N" and "PE". Otherwise, the device may be damaged.
- The cable strands must be inserted completely into the terminal holes. No part may be exposed.
- Ensure that the cables are securely connected. Otherwise, the device may be damaged by overheating during operation.

NOTE

- When making electrical connections, wear personal protective equipment such as safety shoes, protective gloves and insulated gloves.
- All electrical connections should be made by authorised specialists.
- The cable colours in this document are for reference only. Cable specifications must be selected in accordance with regulations.
- To simplify wiring, aluminium wires and solid copper wires are not recommended.

**Wiring specifications**

Model	Cable	Technical data
GW7K-HCA-20	Multi-core three-wire external power cable	<ul style="list-style-type: none"> • Copper, 105 °C, 1,000 V • Outer diameter: 13–14 mm • Conductor cross-sectional area: 6 mm²
GW11K-HCA-20	Multi-core five-core outdoor power cable	<ul style="list-style-type: none"> • Copper, 105 °C, 1,000 V • Outer diameter: 12.6–17.3 mm • Conductor cross-sectional area: 2.5–6 mm²
GW22K-HCA-20		<ul style="list-style-type: none"> • Copper, 105 °C, 1,000 V • Outer diameter: 16.3–17.3 mm • Conductor cross-sectional area: 6 mm²

RCBO specifications

Charger model	RCBO Type	RCBO instantaneous trip characteristics	RCBO Trigger current	RCBO Rated current	RCBO Nominal voltage
GW7K-HCA-20	TYPE A	C	30 mA	40 A	AC 230 V (2P)
GW11K-HCA-20				25 A	AC 400 V (4P)
GW22K-HCA-20				40 A	AC 400 V (4P)

6.2 Connection of the RCBO- cable

NOTE

- The following installation instructions apply to devices purchased from the charger manufacturer. For devices from other manufacturers, please refer to their operating instructions.
- Power cable 1 is connected to the mains or the mains output of the inverter, power cable 2 is connected to the mains input of the charger.

Step 1 Prepare the mains cable.

Step 2 Feed the power cable and terminal through the distribution box and screw the power terminal onto the RCBO.

Step 3 Fit the top cover of the RSBO distribution box to protect it from water or foreign objects.

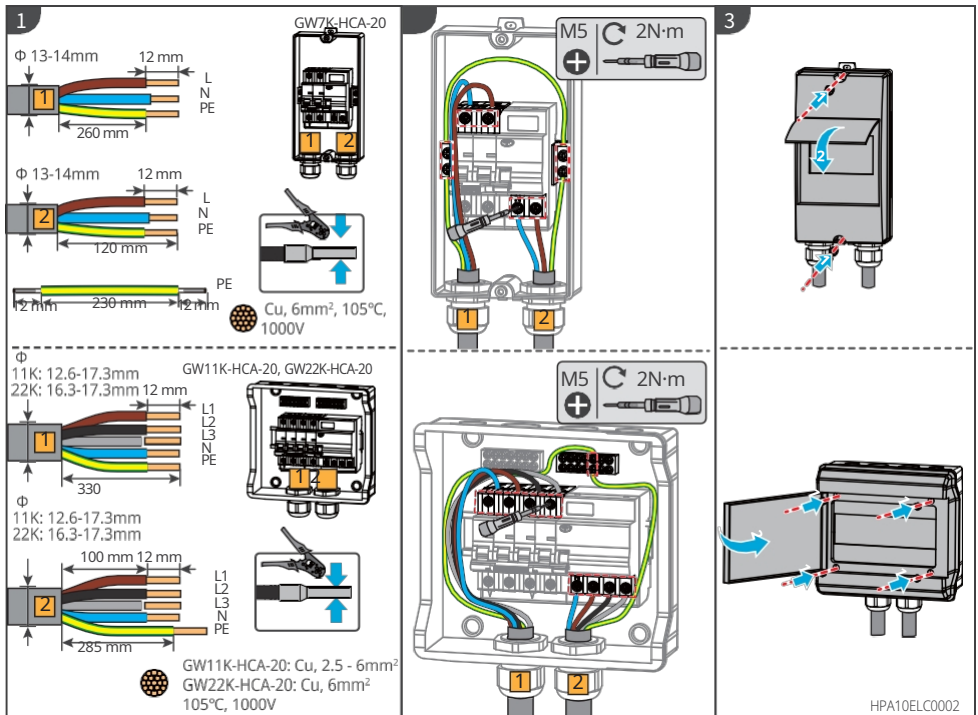

6.3 Connecting the power cable



Connect the single-phase input power cable to the GW7K-HCA-20 charger and the three-phase input power cable to the GW11K-HCA-20 and GW22K-HCA-20 chargers.

1. For GW7K-HCA-20: The voltage is 230 Vac, L/N/PE; the current should be 32 A and the frequency 50/60 Hz.
2. For GW11K-HCA-20: The voltage is 400 Vac, 3L/N/PE; the current should be 16 A and the frequency 50/60 Hz.
3. For GW22K-HCA-20: The voltage is 400 Vac, 3L/N/PE; the current should be 32 A and the frequency 50/60 Hz.

The following illustration uses the three-phase power cable L1, L2, L3, N, PE as an example. The single-phase power cable consists of L, N, PE.

Step 1 Prepare the power cord.

Step 2 Insert the input power cables into the power terminals and tighten them.

Step 3 Secure the mains input terminal in the charger.

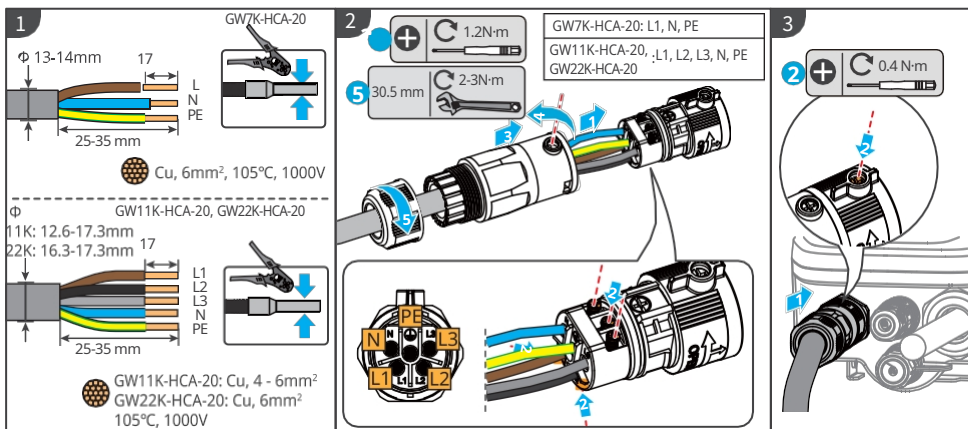

HPA10ELC0001

6.4 e Communication Cable Connection

NOTE

- When connecting the communication line, ensure that the cable connection and device definitions match completely, and the cable alignment path should avoid sources of interference, power lines, etc., so as not to affect signal reception.
- The free connections must be sealed so that the protective function of the charger is not impaired.
- The RS485_A1/B1 ports on the charger are used to communicate with the inverter. For information on the specific RS485 port on the inverter, please refer to the corresponding inverter manual.
- After switching on the devices, please check whether the inverter connection status in SolarGo is continuously green. Otherwise, the inverter connection will fail.

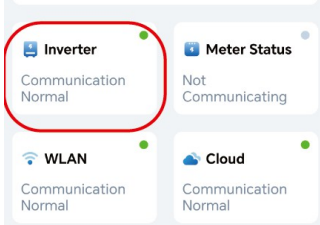

Type one

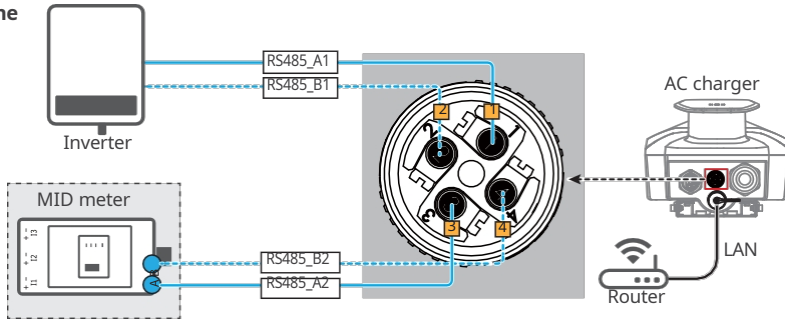

Type two

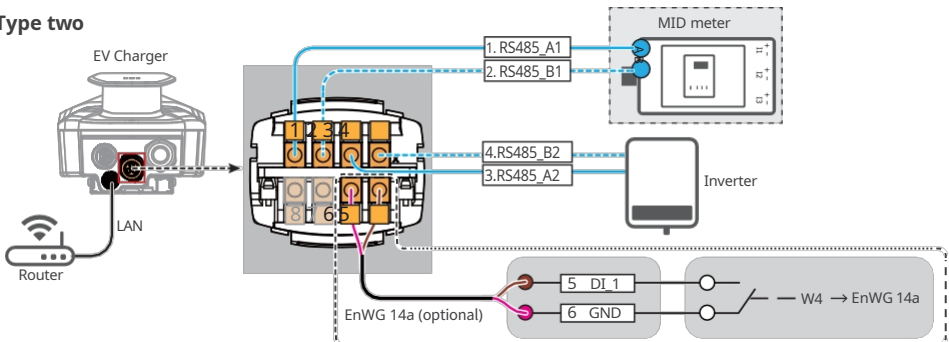



Inverter type	Series/power range	Model		ARM software version	
On-grid inverter	SDT G2	GW5K-DT	GW6K-DT	59,183 or higher	
		GW8K-DT	GW10KT-DT		
		GW12KT-DT	GW15KT-DT		
	Inverter	GW4000-SDT-30	GW5000-SDT-30	05.56 or higher	
		GW6000-SDT-30	GW8000-SDT-30		
GW10K-SDT-EU30		GW12K-SDT-30			
GW15K-SDT-30		GW17K-SDT-30			
GW20K-SDT-30	GW25K-SDT-30	GW27K-SDT-30	GW20K-SDT-31	GW25K-SDT-P31	GW30K-SDT-C30
	GW50K-SDT-C30		0,6 or higher		
	GW5000-SDT-AU30	GW6000-SDT-AU30	0,0 or higher		
	GW8000-SDT-AU30	GW9990-SDT-AU30			
	GW15K-SDT-AU30	GW20K-SDT-AU30			
	GW25K-SDT-AU30	GW29K9-SDT-AU30		GW25K-SDT-30	GW30K-SDT-30
Hybrid inverter	ET G1 (5-10kW)	GW5K-ET	GW6.5K-ET	30,290 or higher	
		GW8K-ET	GW10K-ET		
		GW10KL-ET	GW8KL-ET		
		GW5KN-ET	GW8KN-ET		
		GW10KN-ET	GW5KL-ET		
		GW6KL-ET	GW6.5KN-ET		
	ET G2 (6-15 kW)	GW6000-ET-20	GW8000-ET-20	13,436 or higher	
		GW9900-ET-20	GW10K-ET-20		
GW12K-ET-20		GW15K-ET-20			
ET (15-30kW)	GW12KL-ET	GW15K-ET	13,436 or higher		
	GW18KL-ET	GW20K-ET			
	GW29.9K-ET	GW30K-ET			
	GW25K-ET				
ES G2 (3-6 kW)	GW3000-ES-20	GW3600-ES-20	10.427 or higher		
	GW5000-ES-20	GW6000-ES-20			
	GW3600M-ES-20	GW5000M-ES-20			
	GW6000M-ES-20	GW3500L-ES-BR20			
	GW3600-ES-BR20	GW6000-ES-BR20			

6.4.1 Connecting the RS485 communication cable

NOTE

- Please prepare your own twisted pair cable for outdoor use that complies with local standards.
- If the RS485 port is free, please seal the connector with the supplied waterproof rubber plug and connect the connector to the charger.

Step 1 Prepare the communication cable

Step 2 Attach the cable to the port.

Step 3 Connect the plug to the charger.

Type one

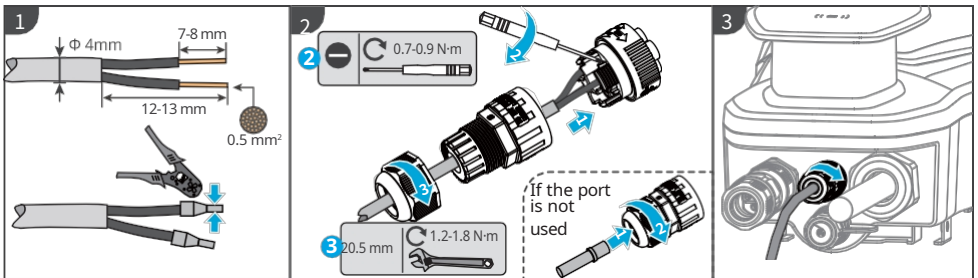

Type two

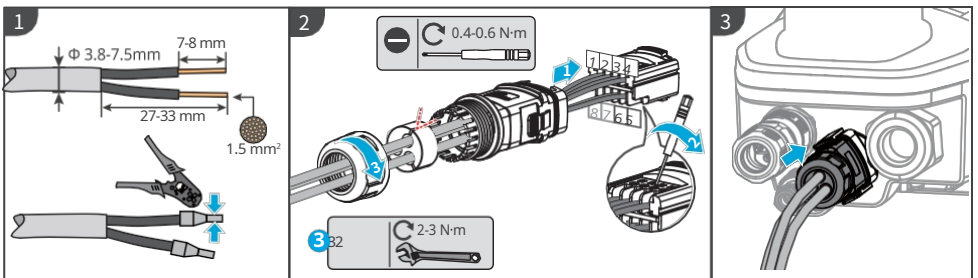

HCA20ELC007



6.4.2 Connection of the LAN communication cable

NOTE

- Please prepare the communication cable yourself.
- If the LAN-2 connection is free, please seal the plug with the waterproof rubber plug provided and connect the plug to the charger.

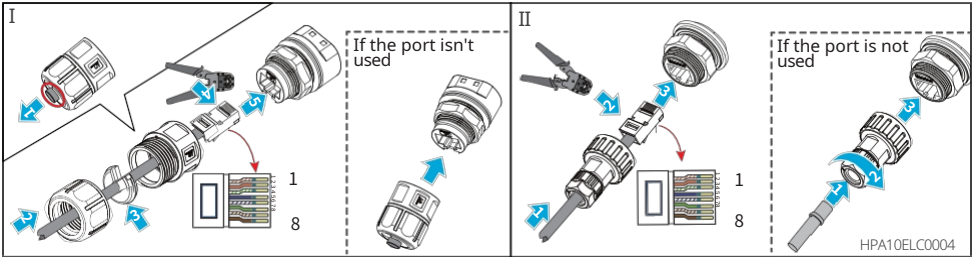

6.4.3 Connecting the MID meter cable (optional)

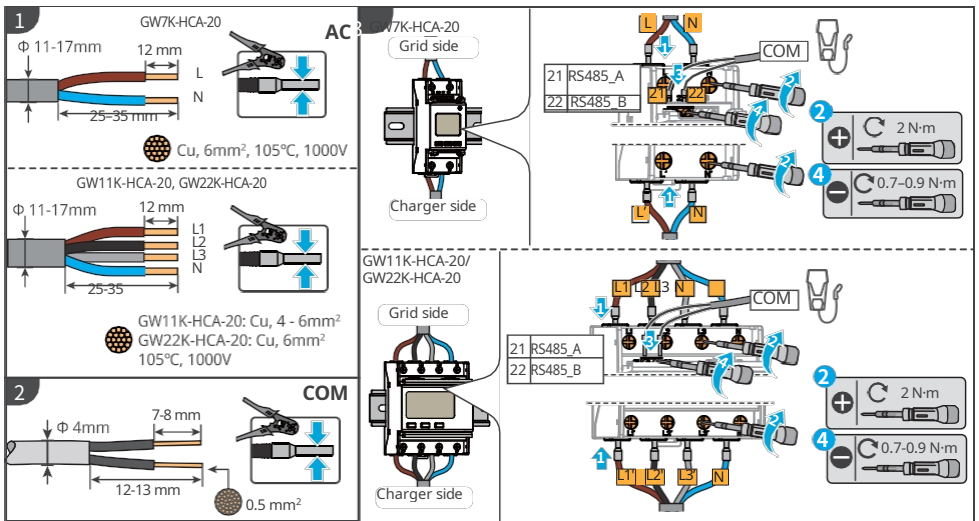

7 Commissioning

7.1 Checks before switching on the

No	Check
1	The charger is permanently installed in a clean, well-ventilated and easily accessible location.
2	The mains input and all communication cables are connected correctly and securely.
3	The cable ties are intact, properly and evenly laid.
4	Unused connections and terminals are properly sealed.
5	Voltage, frequency and other mains parameters comply with the operating requirements of the charger.

7.2 Switching operation

Connected to the mains

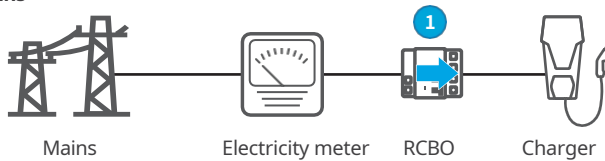

Switch on the RCBO between the charger and the mains.

Connected to PV string and batteries

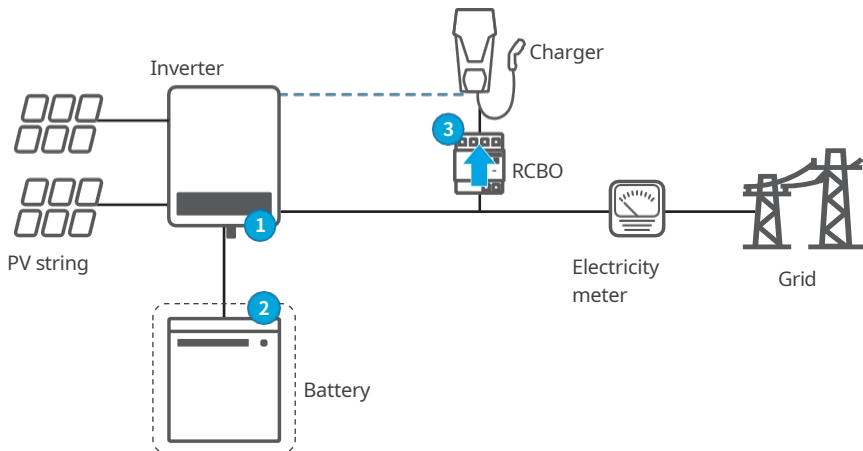

Step 1 Switch on the switches for alternating current and direct current on the inverter side.

Step 2 (Optional) Switch on the switches on the battery side.

Step 3 Switch on the RCBO.



7.3 Charging electric vehicles



- Do not move the EF during charging.
- Press the emergency stop button to disconnect the power supply if a fault occurs during charging.
- Do not charge on stormy or rainy days. Check that the charging plug and EF charging port are dry when charging is necessary.
- Keep children away from the charger. Children must not use the charger.
- If there is a fault or the cable is broken, charging the EF is not permitted.

NOTE

- Insert the charging plug into the EF charging connector before starting the charging process.
- When charging is complete, unplug the charging plug and replace the cap. Wrap the cable around the dummy socket or charger.
- If the EF does not support automatic charging, you must reconnect the charger's charging plug to restart the interrupted charging process:
 - for AUTO start mode, plug the charging connector back in and the charging process will restart;
 - For other modes, the charging process can be restarted by tapping the card or starting the app.

7.3.1 Online charging via SolarGo or the SEMS portal app

SolarGo

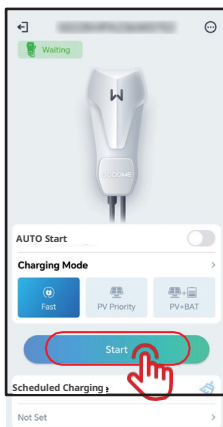

SEMS

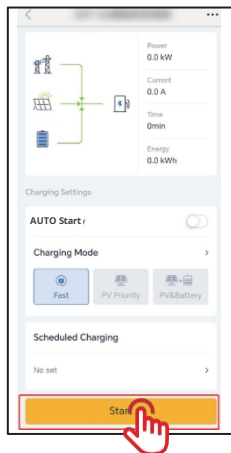

7.3.2 Scheduling charging via the SolarGo or SEMS portal app

SolarGo:

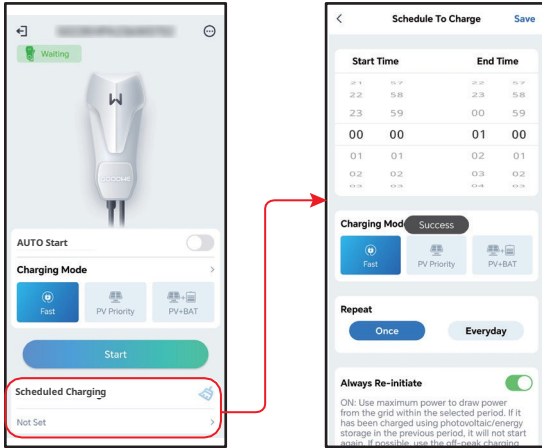

SEMS:

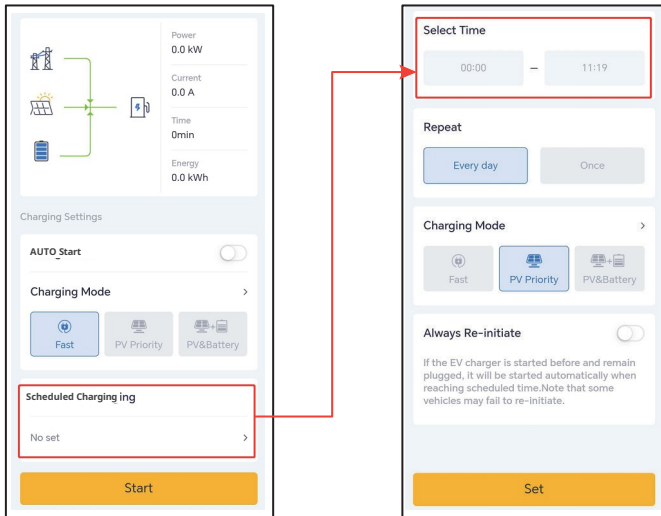



7.3.3 AUTO Start

When AUTO Start mode is activated, the car begins charging as soon as the charging plug is inserted, without the need to swipe an RFID card, provided that no scheduled charging process has been set.

SolarGo

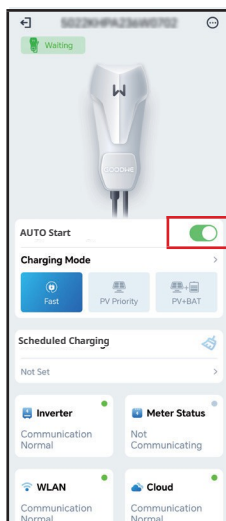

SEMS

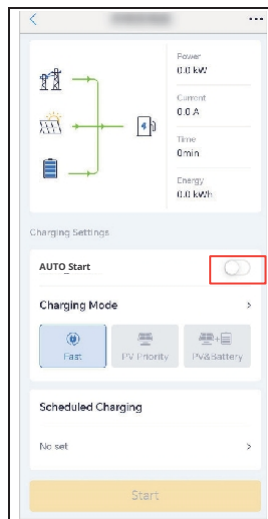

7.3.4 Charging via the RFID card

NOTE

- The RFID card must be linked to the charger in advance. For information on the linking steps, see sections 8.2.6 or 8.3.6.
- The correct sequence is: plug the charging connector into the electric vehicle and then tap the card.

After you have tapped the card, the charger will start charging the electric vehicle.

8 System commissioning

8.1 Display

Display	Colour	Explanation
	Green ON	The charger is in standby mode.
	Green flashing	The charger is being upgraded.
	Blue ON	The charger is charging.
	Red ON	An error has occurred.
	The status of the indicator light in the event of abnormal activation of the RFID card charging process	
	Red light illuminates for 2 seconds	Tap the card before connecting the charging plug to the EF.
	Red light flashes twice	Charger and card do not match.

8.2 Setting and monitoring charger data via the SolarGo app (Installations)

8.2.1 Downloading and installing the app

Your mobile phone must meet the following requirements:

- Mobile phone operating system: At least Android 4.3 or iOS 9.0.
- The mobile phone must be able to access the internet.
- The mobile phone supports Wi-Fi or Bluetooth.

Method 1: Search for "SolarGo" in Google Play (Android) or the App Store (iOS) to download and install;



Method 2: Scan the QR code and download the app to install it.





NOTE

This document is based on SolarGo version 6.5.0. The content may vary depending on the SolarGo version.

8.2.2 Registering the charger

NOTE

- When logging in for the first time, use the initial password and change it as soon as possible. For account security, the password should be changed regularly and the new one should not be forgotten.
- If the password is entered incorrectly three times, the account will be locked. You can contact GOODWE After-Sales Service to obtain the super password. After logging in, please change the login password.

Step 1 Check that the charger is switched on and working correctly.

Step 2 On the SolarGo app home page, select the **Bluetooth** tab.

Step 3 Pull down or tap **Search Device** to refresh the device list. Find the device using the serial number of the inverter. Tap the device name to log in on the **Home page**.

Step 4 (optional): When connecting to the device via Bluetooth for the first time, a Bluetooth pairing prompt will appear. Confirm by tapping **Pair**.

Step 5 The home page is accessed by entering the login password. Initial password: goodwe2022.

Step 6 (optional): If the original password is used, the app will prompt you to change it after logging in. Change it as needed.

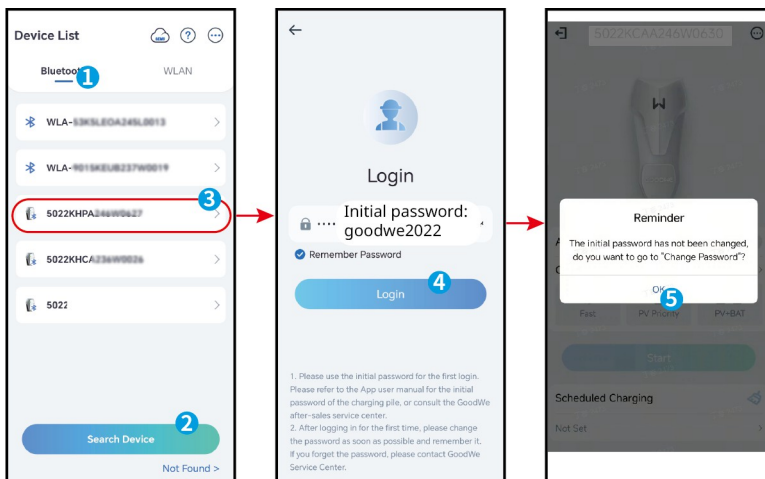

8.2.3 Introduction to the main page

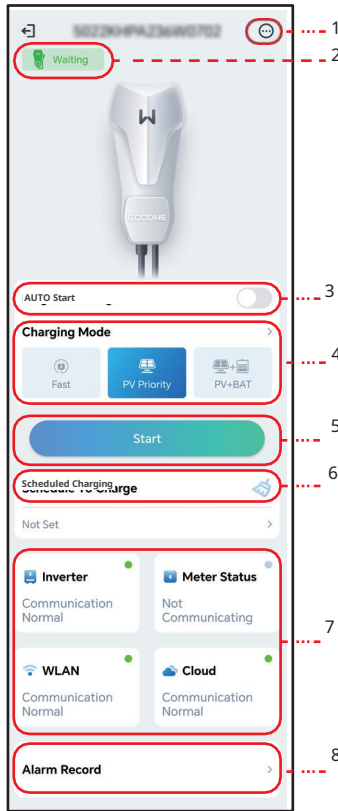

No.	Name/symbol	Description
1	More	Configure the charger. For example, WiFi configuration, ensure minimum charging power, etc.
2	Device status	Charger status, e.g. Idle (plugged), Charging, etc.
3	AUTO Start	Charging begins immediately after plugging in the charging connector.
4	Charging Mode	Select the charging mode for electric vehicles.
5	Start/End Charging	<ul style="list-style-type: none"> Start charging: Begin charging the electric vehicle. End charging: Stop charging the electric vehicle.
6	Scheduled Charging	Set the single or cycle charging time.
7	Communication Status	<p>Inverter: Check whether the charger is communicating with the inverter.</p> <p>Meter: Check whether the charger is communicating with the meter.</p> <p>WiFi: Check whether the charger is connected to the router.</p> <p>Cloud: Check whether the charger communicates with the cloud.</p>
8	Alarm Record	Alarm check

8.2.4 Configure Wi-Fi

Configure the router data or the switch that communicates with the charger so that communication between the charger and the router or switch remains stable. Otherwise, the charger will not be able to connect to the server.

Step 1 To configure the parameters, tap **More > Communication Setting**. **Step 2** Tap **Network Name** and select the correct network. Enter the **password** for the selected network.

Step 3 Enable or disable **DHCP** as required.

Step 4 Configure the **IP Address**, **Subnet Mask**, **Gateway Address**, and **DNS Server** according to the router or switch specifications if **DHCP** is disabled.

Step 5 Tap **Save** to save the settings.

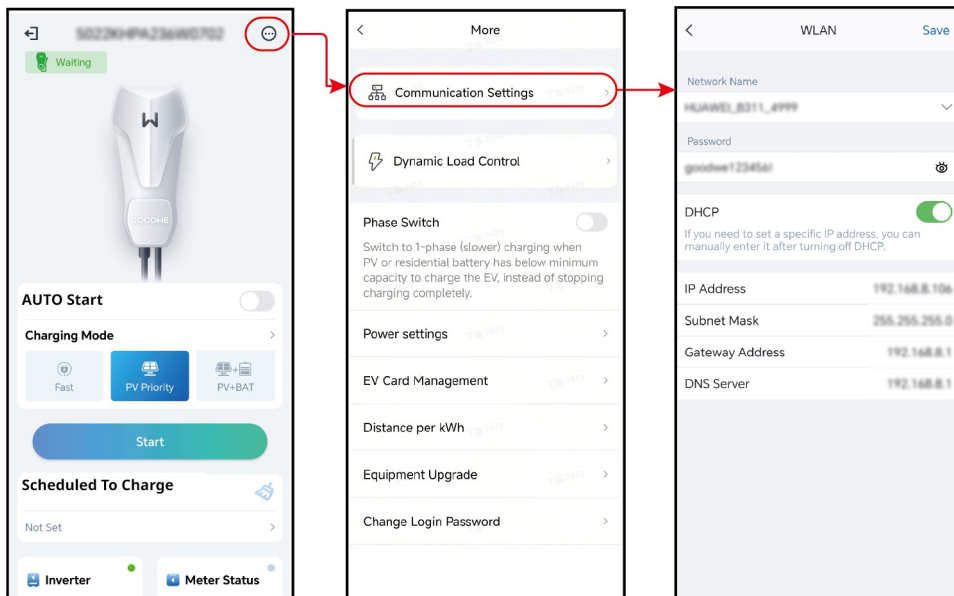

No.	Parameter	Description
1	Network Name	Select a network in which you want to establish communication between the charger and the router or network switch. The charger can then be connected to the cloud.
2	Password	Wi-Fi password for the currently connected network.
3	DHCP	<ul style="list-style-type: none"> • Enable DHCP if the router is in dynamic IP mode. • Deactivate DHCP if a switch is used or if the router is in static IP mode.
4	IP Address	<ul style="list-style-type: none"> • Do not configure the parameters if DHCP is enabled. • Configure the parameters according to the router or switch specifications if DHCP is disabled.
5	Subnet mask	
6	Gateway Address	
7	DNS Server	

8.2.5 Configuring the charging mode for the

There are three charging modes: Fast, PV Priority and PV+Battery.

Fast

The charger uses electricity from the mains, PV or batteries to charge electric vehicles. The output power of the charger corresponds to the nominal output power of the charger by default. Users can set an output power that does not exceed the nominal output power.

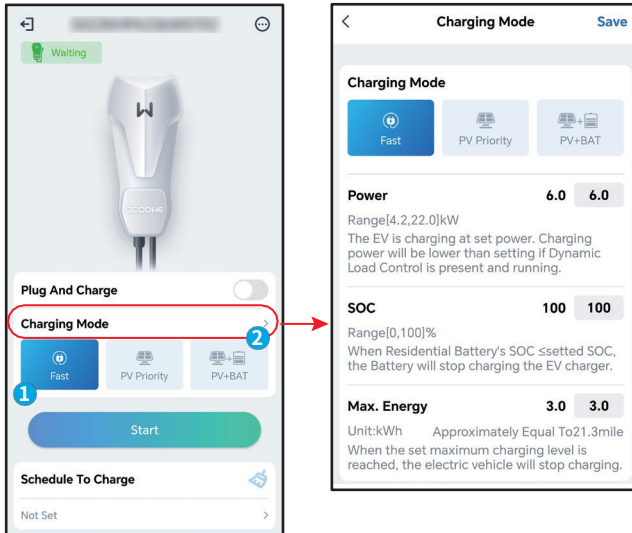

PV priority

Only PV power is used to charge the electric vehicle. Loads that may be grid loads or emergency power loads take priority in PV power consumption. The remaining power is used to charge the electric vehicle.

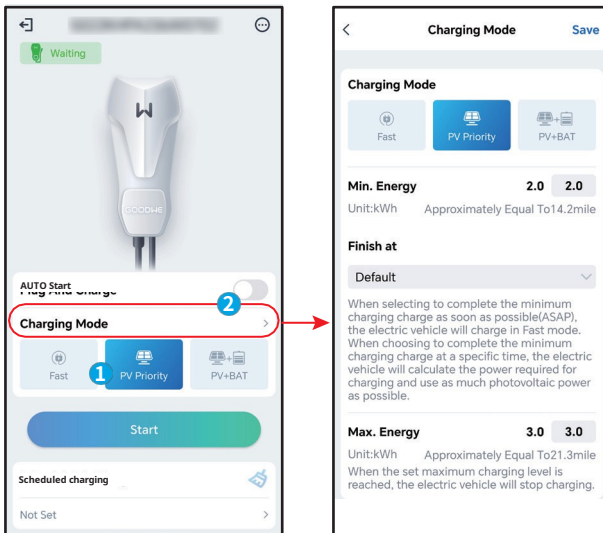



PV + Battery

The PV output and the battery are used to charge the electric vehicle. Loads, which may be grid loads or emergency loads, have priority in terms of power consumption. The remaining power is used to charge the electric vehicle.

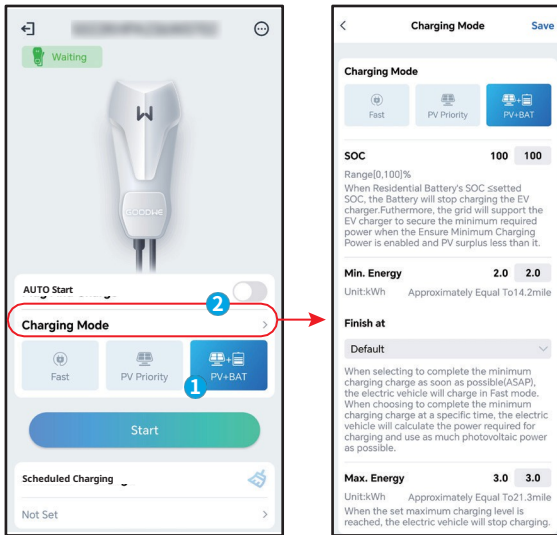

8.2.6 More

Dynamic Load Control

After switching on dynamic load control, the charger uses the meter data received and the set mains connection current to balance the charging speed (or even pause the charging process) in order to prevent the main fuse from tripping. If the actual current drawn is close to the set mains connection current, the charger reduces the charging power until the charging process is interrupted to prevent tripping. The charger restarts automatically as soon as the difference between the set mains connection current and the current drawn from the mains meets the charger's start conditions.

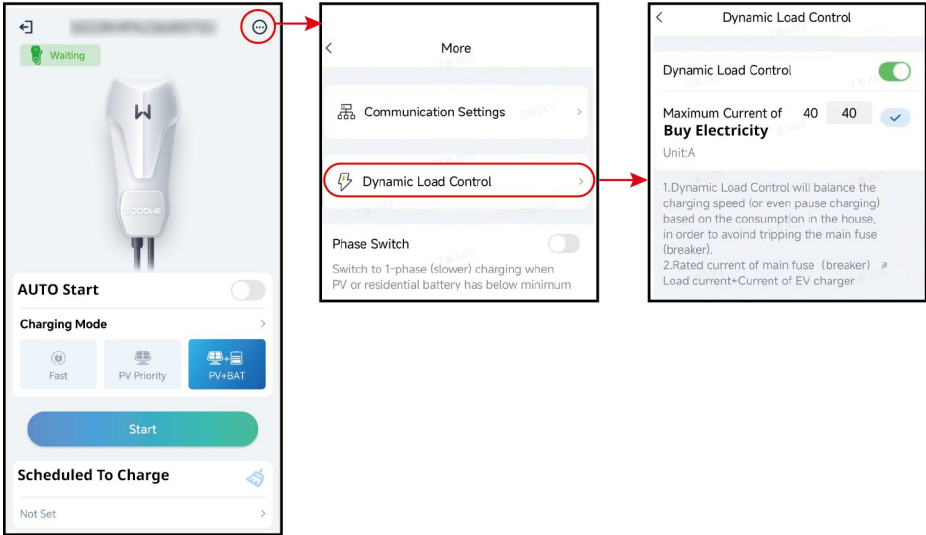



Phase switch

NOTE	
The phase switch function is only available for three-phase chargers.	

Status	Explanation
ON	If the total input power is less than 4.2 kW, the charger switches automatically switches to single-phase charging mode to avoid purchasing electricity from the grid or shutting down. The minimum charging power in single-phase charging mode is 1.4 kW. (The phase switching time is approx. 3 minutes)
OFF	The charger remains in three-phase charging mode.

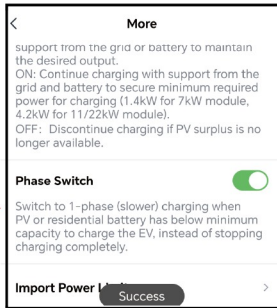
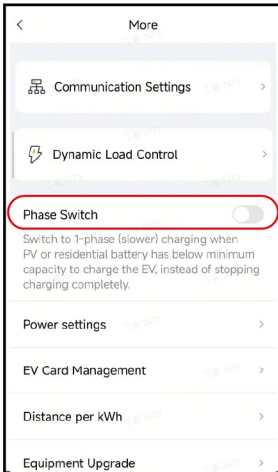

Power settings

Step: Tap More > Power Settings to set the relevant parameters.

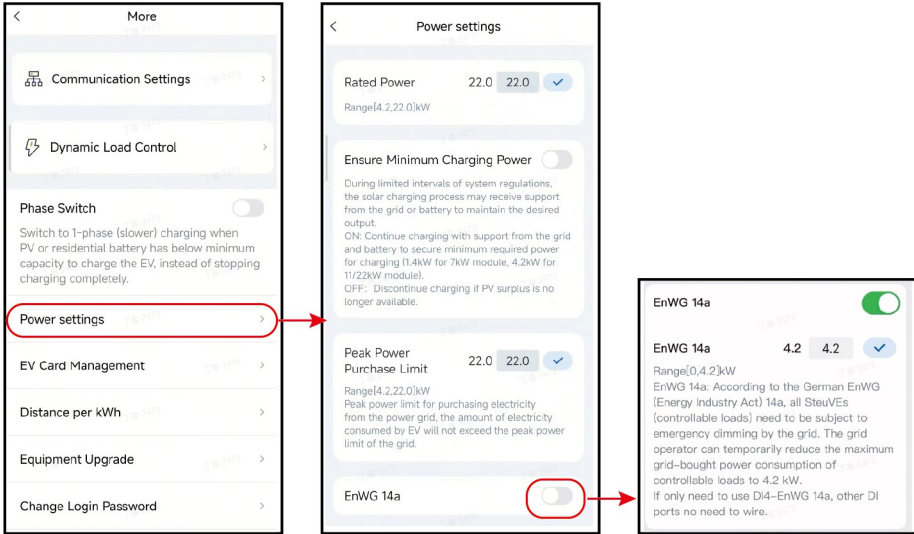

No	Parameter	Descriptions
1	Nominal power	Set the charging power of the charging station. If not specified, the default charging power is the rated power.
2	Ensuring minimum charging power	During limited intervals of system regulation, the solar charging process can receive support from the mains or the battery in order to maintain the desired power. ON: Continue charging with support from the grid and the battery to ensure the minimum required charging power (1.4 kW for 7 kW module, 4.2 kW for 11/22 kW module). OFF: Stop charging when the PV surplus is no longer available.
3	Peak power	Peak power limit for purchasing electricity from the grid; the amount of electricity consumed by the EV does not exceed the peak power limit of the grid.
4	EnWG 14a	According to the German Energy Industry Act (EnWG) 14a, all controllable loads (SteuVEs) must be subject to emergency dimming by the grid. The grid operator can temporarily reduce the maximum grid-related electricity consumption of controllable loads to 4.2 kW. If only DI4 - EnWG 14a needs to be used, the other DI ports do not need to be wired.



Electric vehicle card management

RFID cards can be added and deleted; each charger can be linked to up to 10 cards.

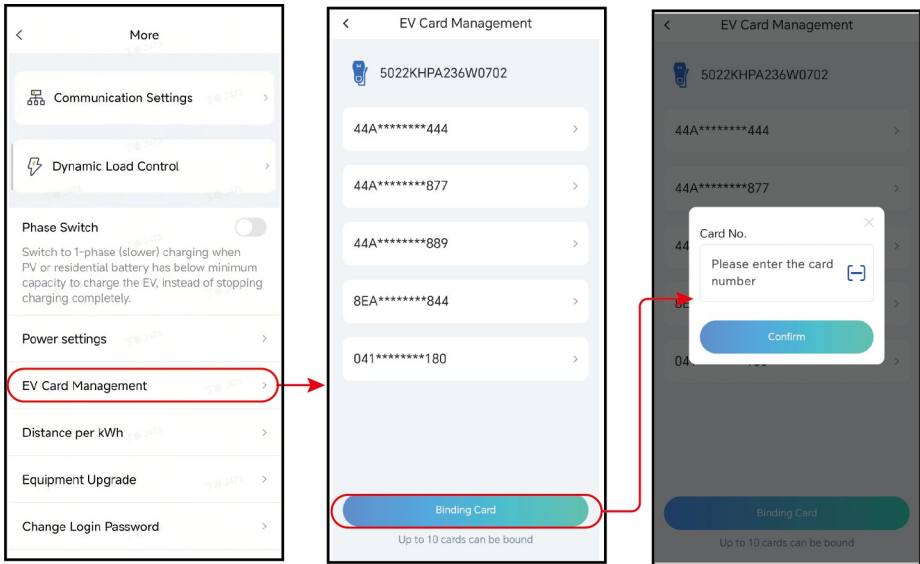

Distance per kWh

You can set the conversion ratio for energy and mileage or keep the default setting.

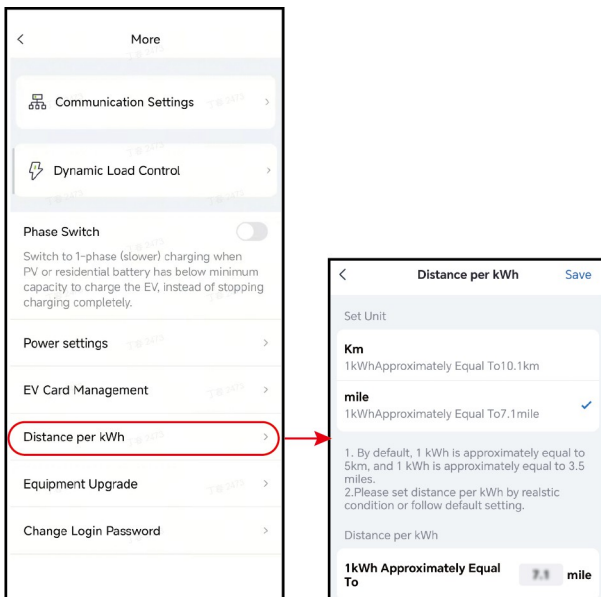

Devices - Upgrade

Step: Tap More > Devices - Upgrade to upgrade the EV charger.

Change login password

Step: Tap More > Change Login Password to change the password.

Restore factory settings**NOTE**

After restoring factory settings, the password will revert to the original password goodwe2022.

Step: Tap More > Restore Factory Settings.



8.3 Setting and controlling charger data via the SEMS portal app (installations)

8.3.1 Downloading and installing the app

Mobile phone requirements:

- Operating system: Android 4.3 or later; iOS 9.0 or later.
- Suitable for internet connection and online surfing.
- Suitable for connecting to Wi-Fi/Bluetooth.

Method 1 Search for "SEMS Portal" in Google Play (Android) or the App Store (iOS) to download and install;



Method 2 Scan the following QR code to download and install.



8.3.2 Registering the end user account

Tap **Register** and fill in the registration fields.

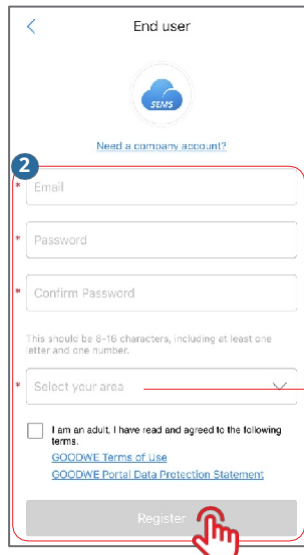
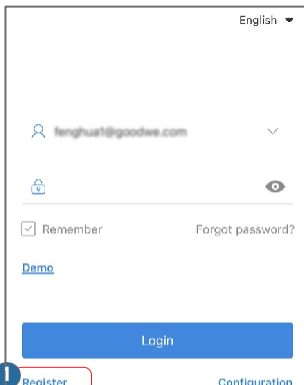

Note: Select **your region** according to the location of the plant. At If the wrong selection is made, the system may not be able to be created.

8.3.3 Logging in to the app

NOTE

Account and password already received.

Enter your account and password, tap **Login** and open the "SEMS Portal" app.

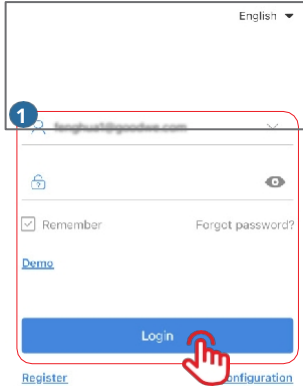

SEMS PORTAL V3.3.17

APPs >

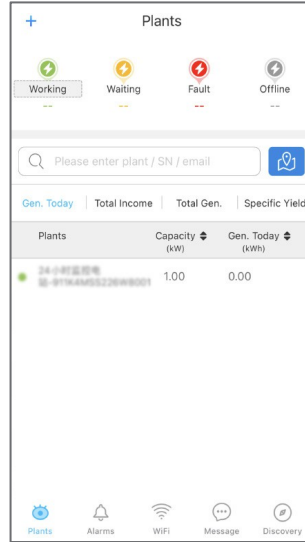



8.3.4 Create an

Step 1 Follow the steps below and go to the **Create Plant** page.

Step 2 Read the instructions, enter the required data and tap **Submit**. (* refers to mandatory fields)

Step 3 Follow the instructions for adding devices and complete the plant setup. (Or tap **ADD** on the main page to add new devices.)

The screenshots illustrate the following steps:

- Plants Page:** Shows a list of plants with columns for Capacity (kW) and Gen. Today (kWh). A red hand icon points to the '+ Add' button at the top left.
- Create Plant Form:** A form with the following fields:
 - Owner's Email
 - Plant Name (with a red asterisk indicating it's mandatory)
 - Please select the address
 - Classification: Residential
 - Capacity: Enter plant capacity kW
 - Module: Amount of solar panels
 - Profit Ratio: 2 CLP/kWh
 - Upload Photos: A button with a plus sign
 - Submit: A blue button at the bottom
- Summary Dashboard:** Shows a total of 0.00 kW. It includes a flow diagram with values: 248.5(W) input, 39% conversion, 238.5(W) output, and 10(W) load. It also shows 'In-house' and 'Buy' consumption at 0.00 kWh, and 'Load consumption' and 'Sell' at 0.00 kWh. Contribution and Self-Cons. ratios are both 0.0%.
- Settings Menu:** A list of settings including 'Create Plant', 'After-Sales', 'Warranty', 'GDPR Contacts', 'APPs', 'Synchronize', and 'Community'. 'Create Plant' is highlighted with a red hand icon.
- Scan Bar/QR code:** A screen for adding devices via QR code. It has input fields for SN, CheckCode, and Name, and an 'Add Device' button at the bottom.
- Device Add devices:** A screen to select device types: Inverter, Micro Inverter, DataLogger, EV Charger, and a 'Cancel' button. A red hand icon points to the '+ Add' button at the top right.

8.3.5 Configuring the charging mode of the

There are three charging modes: Fast, PV Priority and PV+Battery.

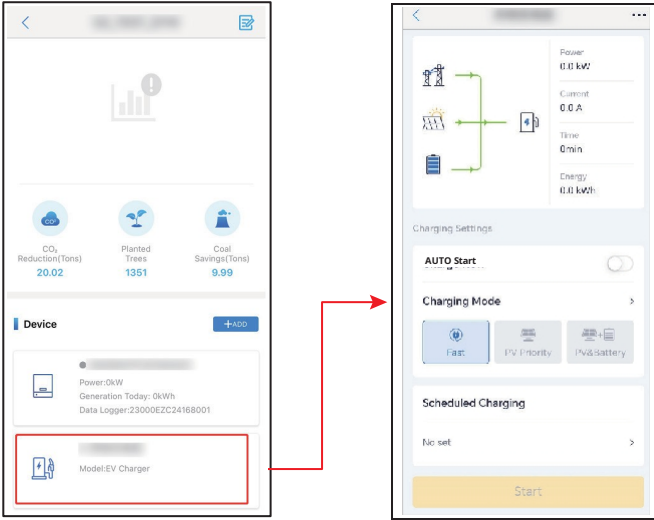

Fast

The charger uses electricity from the mains, PV or batteries to charge electric vehicles. The output power of the charger corresponds to the nominal output power of the charger as standard, and users can adjust the output power according to their actual needs (not exceeding the nominal output power).

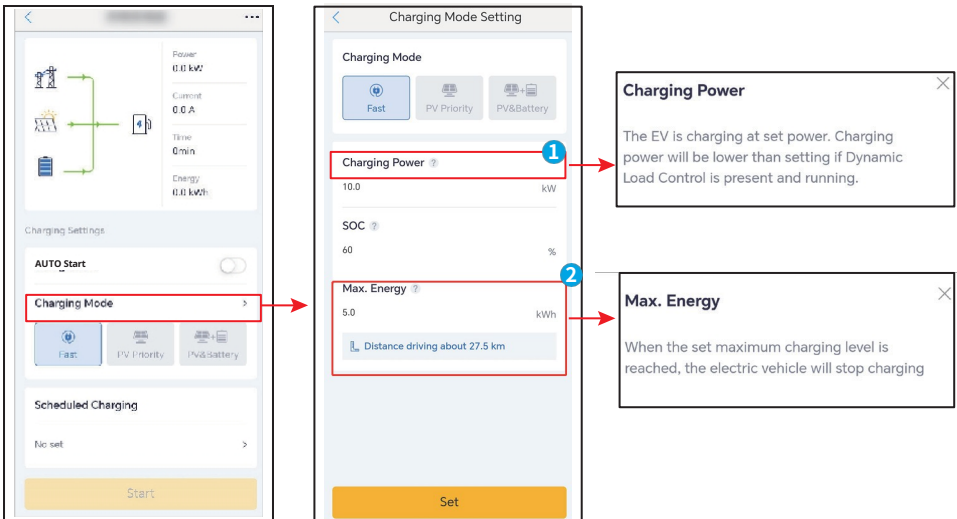



PV priority

Only PV electricity is used to charge the electric vehicle. When it comes to PV electricity consumption, the loads take priority and the remaining power is used to charge the electric vehicle.

The image shows a mobile application interface for charging settings. On the left, a 'Charging Settings' screen displays 'AUTO Start' and 'Charging Mode' options: Fast, PV Priority, and PV&Battery. A red box highlights the 'Charging Mode' section. An arrow points to the 'Charging Mode Setting' screen on the right, which shows 'PV Priority' selected. Two callout boxes are present:

- Min. Top Up**: A red box highlights the 'Min. Top Up' field (set to 2.0 kWh) in the 'Charging Mode Setting' screen. A blue '1' icon is next to it. An arrow points to a callout box explaining: "Minimum amount of charge that the EV needs to get. Depending on the finish time, the power can be supplied from the grid if there is no sufficient PV production, or enough capacity in the residential battery."
- Max. Energy**: A red box highlights the 'Max. Energy' field (set to 3.0 kWh) in the 'Charging Mode Setting' screen. A blue '2' icon is next to it. An arrow points to a callout box explaining: "When the set maximum charging level is reached, the electric vehicle will stop charging"

PV + Battery

The PV power and the battery are used to charge the electric vehicle. When it comes to power consumption, the loads have priority and the remaining power is used to charge the electric vehicle.

The diagram illustrates the configuration of the 'PV + Battery' charging mode. It shows three sequential screens:

- Charging Settings:** The 'Charging Mode' is set to 'PV & Battery'.
- Charging Mode Setting:** This screen allows for detailed configuration of the 'PV & Battery' mode. Three settings are highlighted with callouts:
 - SOC (State of Charge):** Set to 60%. This means the residential battery will be used for charging until the EV's battery reaches 60%. Below this, 'Min. Top Up' is set to 5.0 kWh, with a note 'Distance driving about 27.5 km'.
 - Min. Top Up:** Set to 5.0 kWh. This is the minimum amount of charge the EV needs to get.
 - Max. Energy:** Set to 5.0 kWh. When this maximum charging level is reached, the electric vehicle will stop charging.
- Callout Boxes:**
 - SOC:** The Residential battery will be used to charge the EV until it reaches set percentage. When the SOC is equal to, or lower than, set percentage, the battery will not be used to charge the EV.
 - Min. Top Up:** Minimum amount of charge that the EV needs to get. Depending on the finish time, the power can be supplied from the grid if there is no sufficient PV production, or enough capacity in the residential battery.
 - Max. Energy:** When the set maximum charging level is reached, the electric vehicle will stop charging.



8.3.6 Settings

Dynamic load control

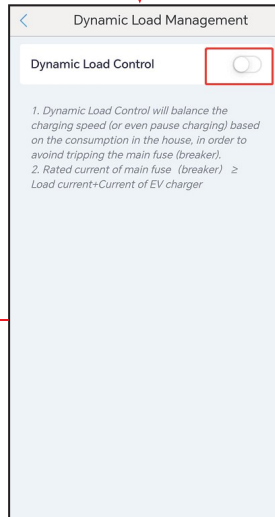
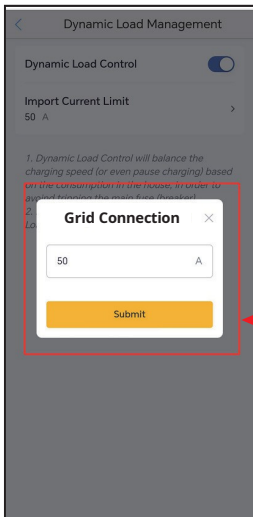
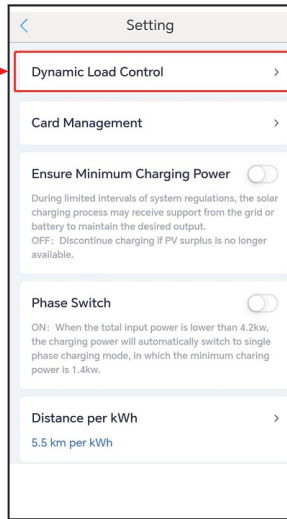
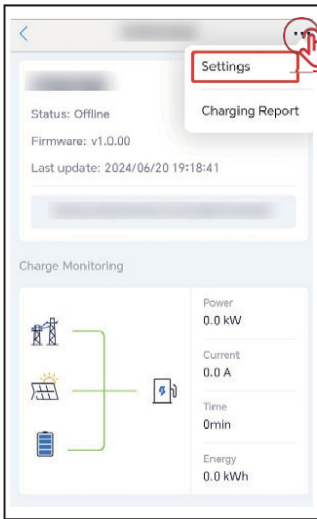

Ensure minimum charging power

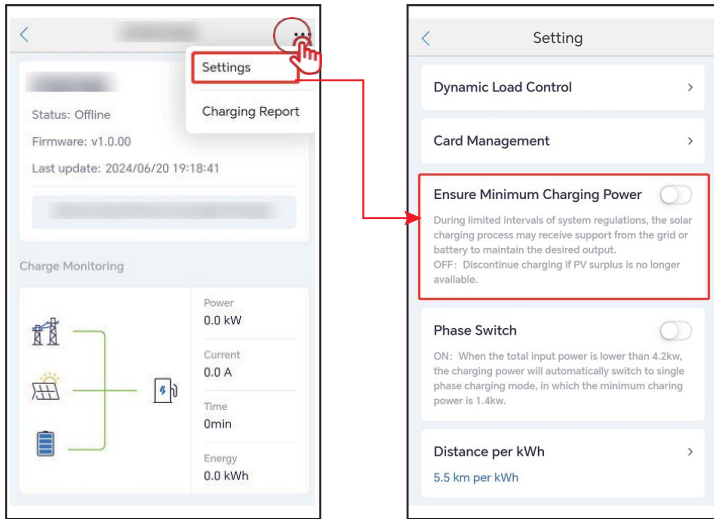



RFID card management

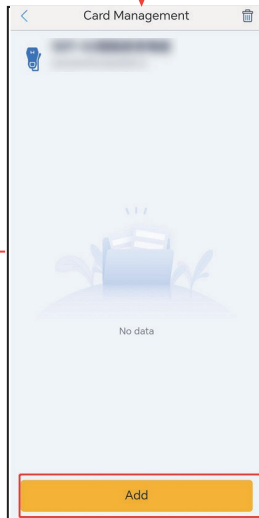
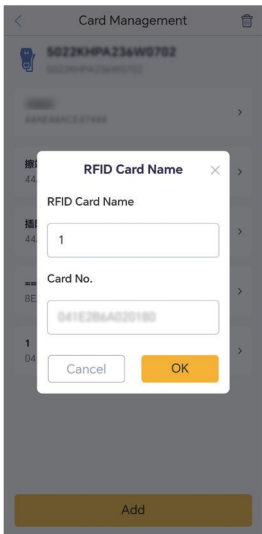
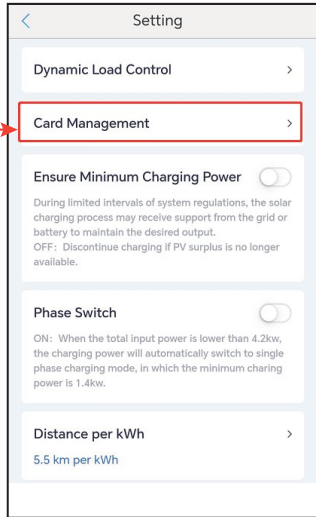
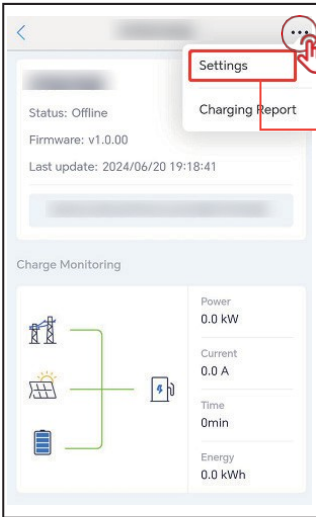

Phase switch

NOTE

The phase switch function is only available for three-phase chargers.

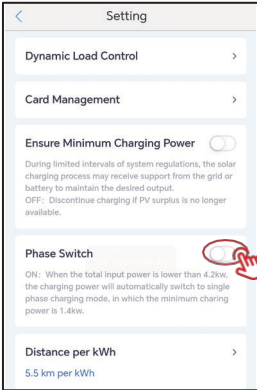

Distance per kWh

You can set the conversion ratio for energy and mileage or keep the default setting.

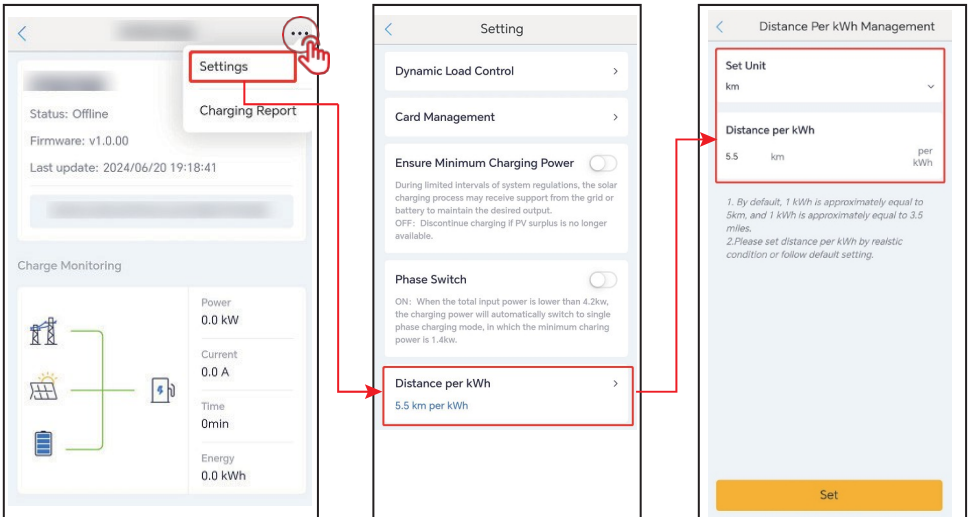



9 Maintenance

9.1 Shutdown



Switch off the charger before performing maintenance. Otherwise, it may be damaged or there is a risk of electric shock.

Disconnect the RCBO between the charger and the mains/inverter.

9.2 Removing the charger



- The device must be switched off.
- Put on the necessary personal protective equipment before starting any work.

Step 1 Disconnect all cables, including the mains and communication cables.

Step 2 Remove the device from the mounting plate.

Step 3 Remove the mounting plate.

Step 4 Store the charger correctly. If the device is to be used again later, the storage conditions must meet the requirements.

9.3 Disposal of the charger

If the device no longer works, dispose of it in accordance with the regulations for electrical waste. The device must not be disposed of with household waste.

9.4 Routine maintenance

Maintenance item	Maintenance method	Maintenance interval
Emergency stop button	Switch the EMS on and off three times in succession and check that it is working correctly.	Every 6 months
Electrical connection	Check that the cables are securely connected. Check that the cables are not broken and that no copper core is exposed.	Every 6-12 months
Seals	Check that all terminals and connections are properly sealed. Re-seal the cable entry if it is not tight or is too large.	Every 6-12 months

9.5 Troubleshooting

The charger displays red when there is a fault. For detailed troubleshooting, log in to the SEMS portal application or the "PV Master" app.

Perform troubleshooting according to the following procedures. If these do not work, contact customer service.

Before contacting customer service, gather the following information so that the problems can be resolved quickly.

1. Device details such as serial number, software version, installation date, time of malfunction, frequency of malfunction, etc.
2. Installation environment, including weather conditions, etc. It is best to include some photos and videos for analysis of the problem.
3. Public power grid situation.

No.	Error	Cause	Remedy
1	Gun connection error	The charger is disconnected during charging.	Reconnect the charger.
2	Emergency stop	The emergency stop button is pressed.	Release the button.
3	Grounding fault	The grounding cable of the mains input is disconnected.	Check the grounding cable and reconnect it.
4	Operating temperature	The temperature of the charger is above 98 degrees.	The fault will disappear after cooling down and the charger will enter standby mode.
5	Overvoltage	The mains input is overvoltage.	The fault is removed once a normal voltage is reached, and the charger enters standby mode.
6	Undervoltage	The mains input is carrying an undervoltage.	
7	Overcurrent	The output connection is short-circuited or overloaded.	The fault is cleared at normal output current and the charger enters standby mode.
8	Deviation timeout	<ol style="list-style-type: none"> 1. The battery of the electric vehicle is fully charged. 2. The ambient temperature is too low and the battery cannot be charged. 3. The charger connection is faulty. 	<ol style="list-style-type: none"> 1. Check the battery charging process via the software. 2. If the ambient temperature is too low, start the electric vehicle approximately 5 minutes before charging to allow it to warm up. 3. Check the charging plug, unplug it and plug it back in after about 15 seconds.

No.	Error	Cause	Remedy
9	Preparation time exceeded	Communication of the CP signal is disrupted.	<ol style="list-style-type: none"> 1. Check that the EF is fully charged. 2. Reinsert the charging plug after approximately 15 seconds. Contact your dealer or customer service if this does not resolve the problem. If the problem persists, contact your dealer or customer service.
10	Welded contactor fault	The internal component is defective.	Restart the charger. If necessary, contact your dealer or customer service to resolve the problem.
11	Counter failure		
12	Leakage current error		
13	Reading error		
14	EEPROM error		
15	Flash error		
16	Leak detector error		

10 Technical Data

Technical	GW7K-HCA-20	GW11K-HCA-20	GW22K-HCA-20
Input			
Nominal input voltage (V)	230 ^{*3} , L/N/PE	400 ^{*3} , 3L/N/PE	400 ^{*3} , 3L/N/PE
Nominal input current (A)	32	16	32
Nominal mains frequency (Hz)	50/60	50/60	50/60
Output			
Nominal output power (W)	7000	11,000	2200
Nominal output voltage (V)	230	400	400
Nominal output current (A)	32	16	32
Nominal output frequency (Hz)	50/60	50/60	50/60
Protection			
Fault current protection	AC 30mA+ DC 6mA	AC 30mA+ DC 6mA	AC 30mA+ DC 6mA
Overcurrent protection	Integrated	Integrated	Integrated
Overvoltage protection	Integrated	Integrated	Integrated
Nominal input voltage (V)	Integrated	Integrated	Integrated
Earth fault protection	Integrated	Integrated	Integrated
Overvoltage protection	Type III	Type III	Type III
Emergency stop	Integrated	Integrated	Integrated
Nominal output power (W)			
Nominal output voltage (V)	-30 ~ +50 ^{*1}	-30 ~ +50 ^{*1}	-30 ~ +50 ^{*1}



Technical data	GW7K-HCA-20	GW11K-HCA-20	GW22K-HCA-20	
Relative humidity	5% ~ 95% (non-condensing)	5% ~ 95% (non-condensing)	5% ~ 95% (non-condensing)	
Max. operating altitude (m)	2000	2000	2000	
Cooling method	Natural convection	Natural convection	Natural convection	
User interface	WLAN+APP, LED	WLAN+APP, LED	WLAN+APP, LED	
Start method	APP, RFID, AUTO start	APP, RFID, AUTO Start	APP, RFID, AUTO Start	
Communication	Bluetooth, WiFi, RS485 (*2), LAN	Bluetooth, WiFi, RS485 (*2), LAN	Bluetooth, WiFi, RS485 (*2), LAN	
Operating mode	Fast charging PV priority PV+BATT Time-controlled charging Dynamic load control	Fast charging PV priority PV+BATT Time-controlled charging Dynamic load control	Fast charging PV priority PV+BATT Time-controlled charging Dynamic load control	
Weight (kg)	5.2 (with 6 m cable) 5.6 (with 7.5 m cable)	5.4 (with 6 m cable) 5.6 (with 7.5 m cable)	6.4 (with 6 m cable) 7.1 (with 7.5 m cable)	
Dimensions (W × H × D) (mm)	208 × 450 × 170		208*450*170	208*450*170

Noise emission (dB)	< 20	< 20	< 20
Standby power (W)	< 6.5	< 6.5	< 6.5
Protection class	IP66*2	IP66*2	IP66*2
Output cable & plug	6 m cable (7.5 m optional) IEC Type 2	6 m cable (7.5 m optional) IEC Type 2	6 m cable (7.5 m optional) IEC Type 2
Accessories	RFID card*2	RFID card*2	RFID card*2
Installation	Indoors or outdoors	Indoors or outdoors	Indoors or outdoors
Communication protocol	Modbus TCP	Modbus TCP	Modbus TCP
Protection	External RCD type A required	External RCD type A required	External RCD type A required
MTBF(h)	100,000	100,000	100,000
Protection class	I	I	I
Mounting method	Wall/floor (stand optional)	Wall/floor (stand optional)	Wall/floor (stand optional)
Certifications	IEC61851-1 IEC62311 IEC62955 AS/NZS 4268:2017 IEC61008-1	IEC61851-1 IEC62311 IEC62955 AS/NZS 4268:2017 IEC61008-1	IEC61851-1 IEC62311 IEC62955 AS/NZS 4268:2017 IEC61008-1
EMC	Class B	Class B	Class B
Country of manufacture	China	China	China

*1: Operating temperature range (°C): Charger: -30~+55 °C, charging plug: 50 °C

*2: Protection class: Charging plug IEC type 2: IP55

*3: For Brazil: 220/380/380 V AC



GoodWe website

GoodWe Technologies Co., Ltd.

 No. 90 Zijin Rd., New District, Suzhou, 215011, China

 www.goodwe.com

 service@goodwe.com



Addresses